



360 USt



295 ft



308 ft



394 ft

NEW

Reaching new heights

LTM 1300-6.4

Mobile crane
Grue mobile

LIEBHERR

Mobile and crawler cranes



Technical data

Caractéristiquestechnique

Dimensions	
Encombrement	3
Mobile crane	
Grue mobile	4-7
Crane data	
Dates de la grue	8
VarioBallast Counterweight radius	
Rayon de contrepoids	9
Counterweight	
Contrepoids	9
On-road driving	
Déplacement sur route	10
Jobsite driving	
Déplacement sur chantier	10
Boom/jib combinations	
Configurations de flèche	11-14
T	15-20
TK/TNZK	21-25
TVK/TVNZK	26-35
TS	36-43
TNZF	44-56
Equipment	
Équipement	57-58
Description of symbols	
Explication des symboles	59
Remarks	
Remarques	60

Dimensions Encombrement

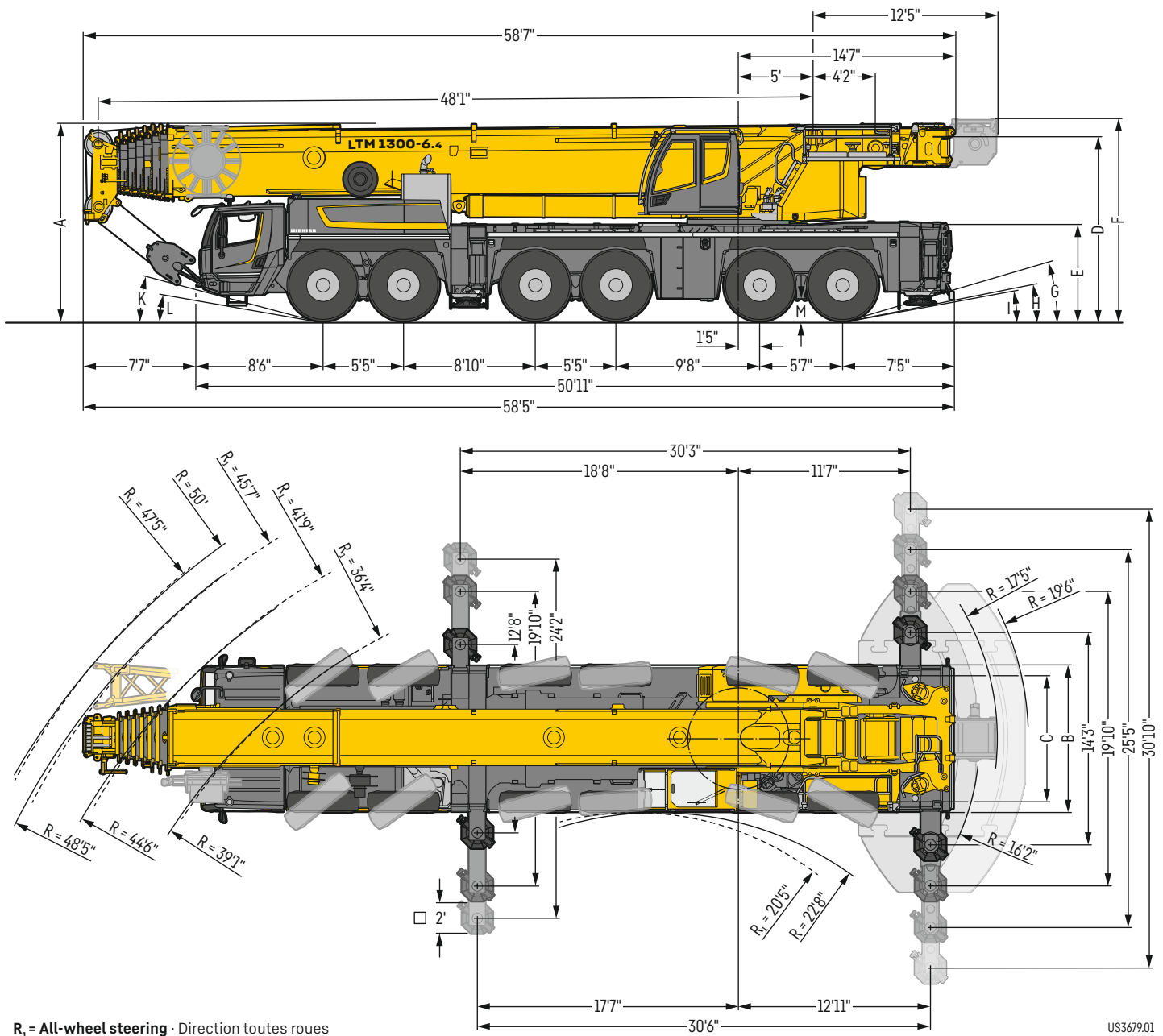

Dimensions · Encombrement

	A	A 5"*	B	C	E	F	G	H	I	K	L	M
445/95 R 25 (16.00 R 25)	13'1"	12'9"	9'10"	8'4"	6'5"	13'6"	16°	11°	10°	14°	9°	1'3"
525/80 R 25 (20.5 R 25)	13'1"	12'9"	10'2"	8'5"	6'5"	13'6"	16°	11°	10°	14°	9°	1'3"

* lowered · abaissé

LTM 1300-6.4

LICCON3

The third generation LICCON control system features the same time-tested operation as previous generations and adds a fast data bus, significantly more storage space and greater computing power. LICCON3 cranes are prepared for telemetry and fleet management.

La troisième génération de la commande LICCON est basée sur la commande éprouvée et marque des points avec un bus de données plus rapide, un espace de stockage nettement plus grand et une puissance de calcul plus importante. Les grues LICCON3 sont préparées pour la télémétrie et la gestion de flotte.



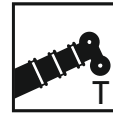

295 ft



38 ft - 66 ft

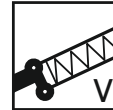

2 x 23 ft



13 ft - 128 ft



26 ft - 141 ft

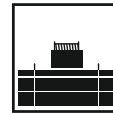

194,000 lb



455 kW (619 h.p.)

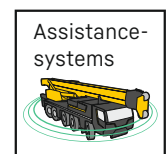
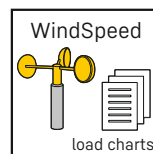
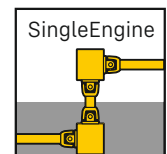
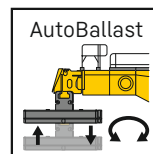
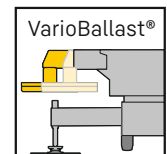
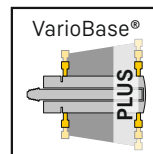

LTM 1300-6.4



1 Powerful hoist winches - 27,425 lb rope pull for fast, powerful hoisting
Treuils de levage robustes - 27,425 lb traction par câble pour des levages rapides et puissants

2 Permanently well lubricated - central lubrication system in the crane's superstructure (standard) and chassis (option).
Une lubrification toujours parfaite - Lubrification centralisée dans la tourelle de la grue (série) et dans le châssis de la grue (option).

3 Well designed ballast distribution - fast ballasting requiring just a few hoists and 92,600 lb of ballast within the vehicle width
Répartition bien pensée du lestage - Lestage rapide en quelques levages, ainsi que 92,600 lb de lestage dans la largeur du véhicule

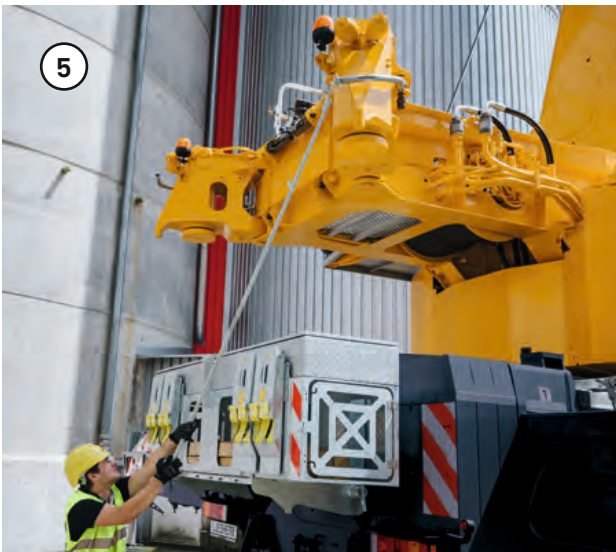

4 Spacious cabins with lots of useful trays and storage compartments.
Cabines avec de nombreuses tablettes et de nombreux compartiments de rangement utiles.





5 VarioBallast® – Higher lifting capacities and greater economy for working with a large radius. Smaller footprint for a smaller radius.
VarioBallast® – Capacités de charge et rentabilité plus élevées avec un grand rayon. Encombrement plus réduit pour un petit rayon.

6 Lightweight – Around 1,100 lb weight reduction from the use of 16.00 R 25 aluminium rims (option)
Poids léger – Réduction du poids d'environ 1,100 lb grâce aux jantes en aluminium 16.00 R 25 (option)









Crane data

Dates de la grue

Hook block • Moufles à crochet



			
374,700 lb	9	16	4,200 lb
343,250 lb	7	14	3,750 lb
275,800 lb	5	11	3,525 lb
180,800 lb	3	7	2,750 lb / 2,200 lb
79,800 lb	1	3	2,200 lb / 1,100 lb
26,900 lb	-	1	1,100 lb

Crane carrier • Châssis porteur









	 min.	 max.	 %		
445/95 R 25 (16.00 R 25)	1.3	53	37.2 %		12 / R2
525/80 R 25 (20.5 R 25)	1.3	53	37.2 %		4 / R2

Theoretical gradeability • aptitude théorique en pente

Max. supporting forces • Forces d'appui max.

		
F _{max}	216,000 lb	271,000 lb

Crane superstructure • Partie tournante

				
 1	0 - 381 ft/min single line • au brin simple	23 mm	1017 ft	27,425 lb
 2	0 - 381 ft/min single line • au brin simple	23 mm	919 ft	27,425 lb
	0 - 1.5 rpm			
	approx. 75 seconds to reach 83° boom angle env. 75 s jusqu'à 83°			
	approx. 750 seconds for boom extension from 48 ft - 295 ft env. 750 s pour passer de 48 ft - 295 ft			

VarioBallast

Counterweight radius

Rayon de contrepoids

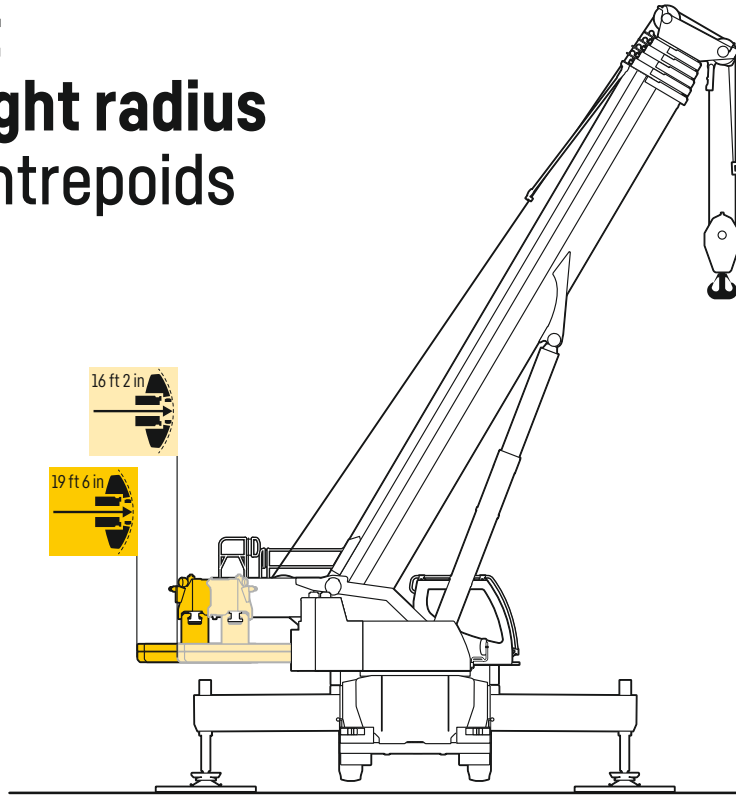
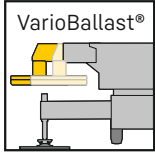

US3541.01

Counterweight

Contrepoids

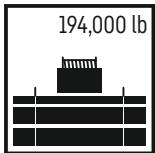

194,000 lb

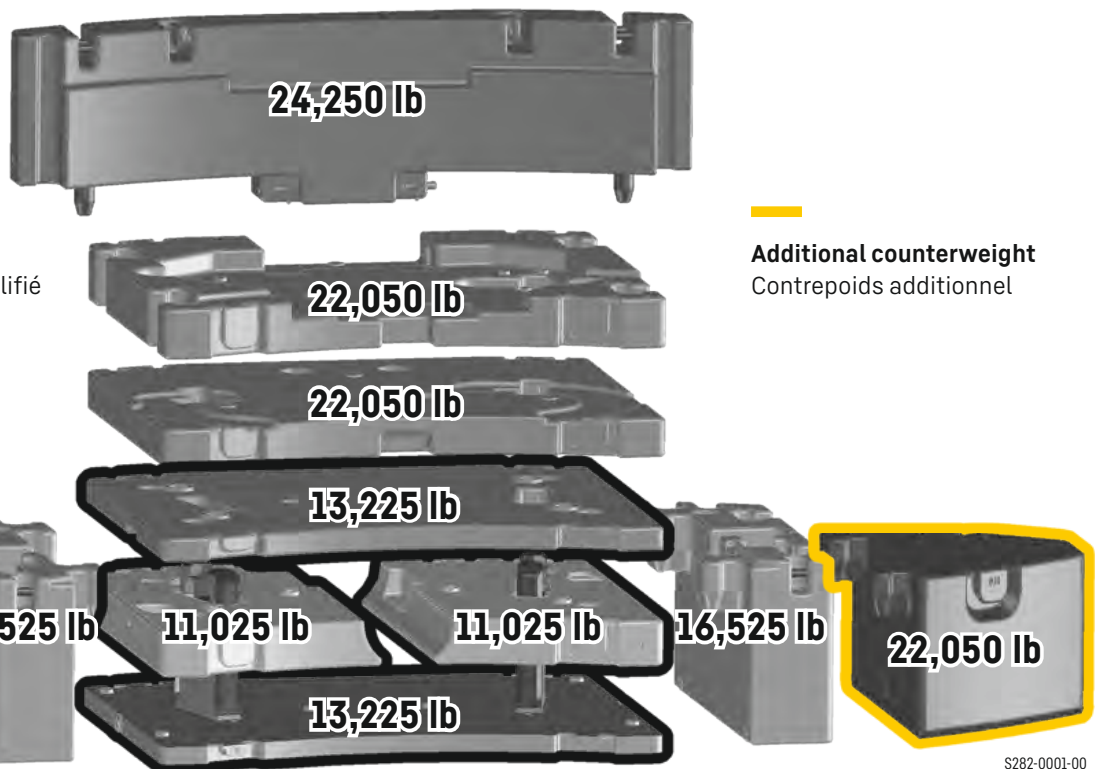

Technically transportable
Transport techniquement simplifié

Additional counterweight
Contrepoids additionnel

S282-0001-00

On-road driving

Déplacement sur route

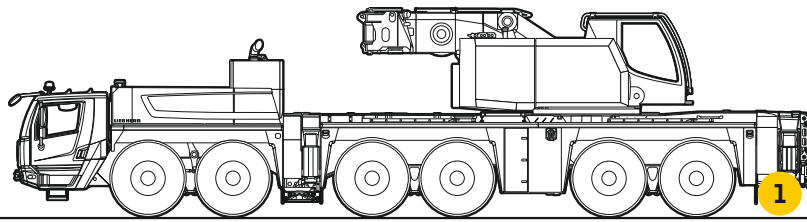

≤ 13,225 lb ≤ 16,525 lb ≤ 16,525 lb
 ≤ 13,225 lb ≤ 16,525 lb ≤ 16,525 lb

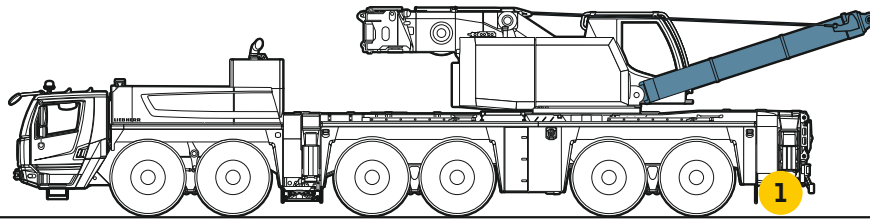
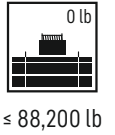

≤ 12,125 lb ≤ 17,650 lb ≤ 17,650 lb
 ≤ 12,125 lb ≤ 17,650 lb ≤ 17,650 lb

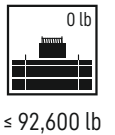

1 Note:
 without rear
 outriggers

Note :
 sans poutres
 coulissantes arrière

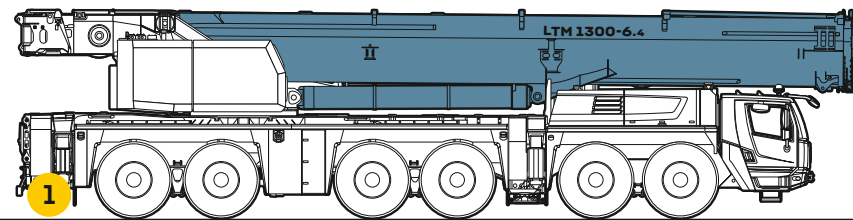

≤ 22,050 lb ≤ 22,050 lb ≤ 16,525 lb
 ≤ 22,050 lb ≤ 22,050 lb ≤ 16,525 lb

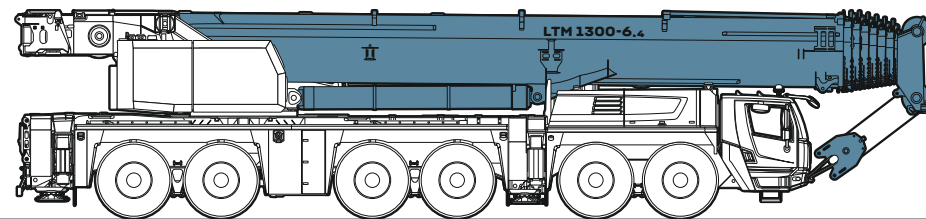
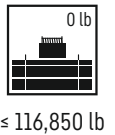

≤ 26,450 lb ≤ 26,450 lb ≤ 26,450 lb
 ≤ 26,450 lb ≤ 26,450 lb ≤ 26,450 lb

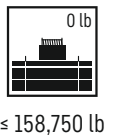

Jobsite driving

Déplacement sur chantier

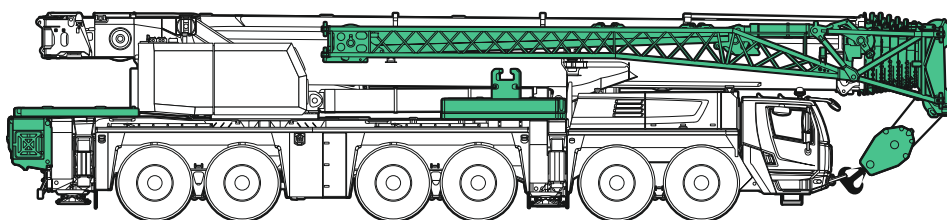

≤ 36,400 lb ≤ 36,400 lb ≤ 36,400 lb
 ≤ 36,400 lb ≤ 36,400 lb ≤ 36,400 lb

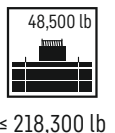

Boom/jib combinations – Strong jib

Configurations de flèche – Flechette particulièrement puissante

TS

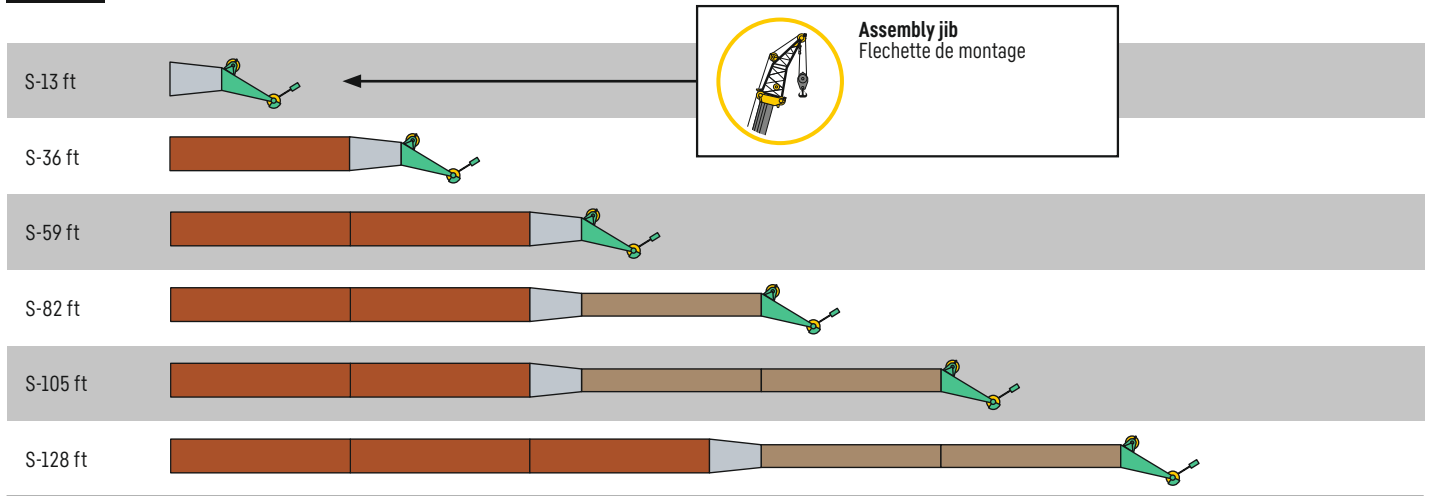

Boom/jib combinations – Hydraulically adjustable fixed lattice jib

Configurations de flèche – Fléchette treillis fixe réglable hydrauliquement

TNZF

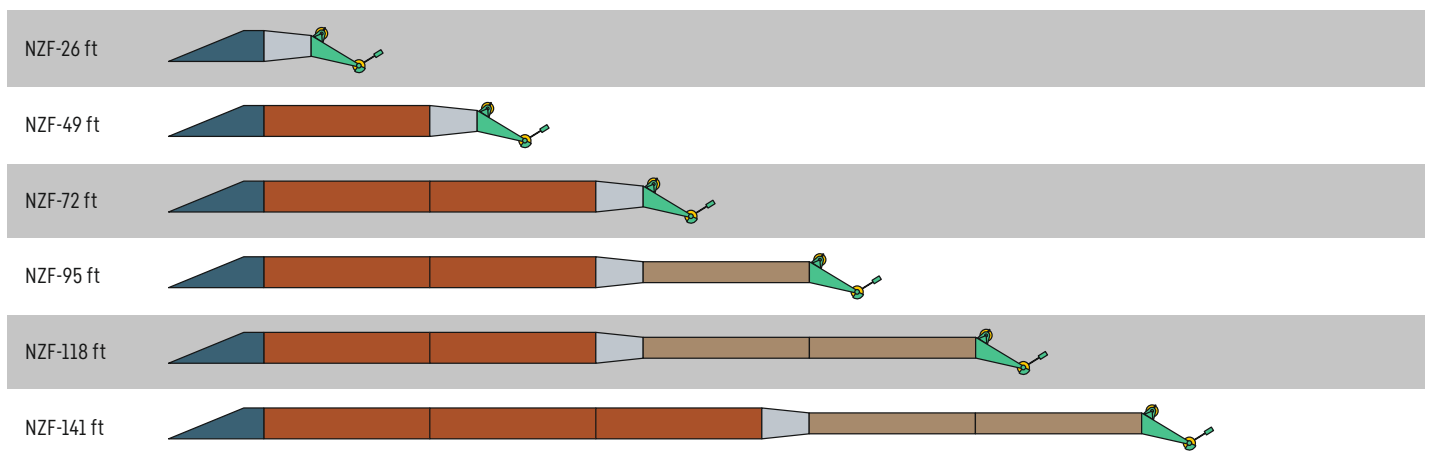

13 ft TF-adapter · TF-adaptateur



23 ft Telescopic boom extension · Rallonge flèche télescopique



6 ft 7 in F reduction section · Élément réducteur F



23 ft Swing away jib extension · Rallonge flechette pliante



6 ft 7 in F head section · Élément de tête F

US3191.01

Variable boom systems

Systèmes de flèche variables

TVK
TVNZK

TNZF

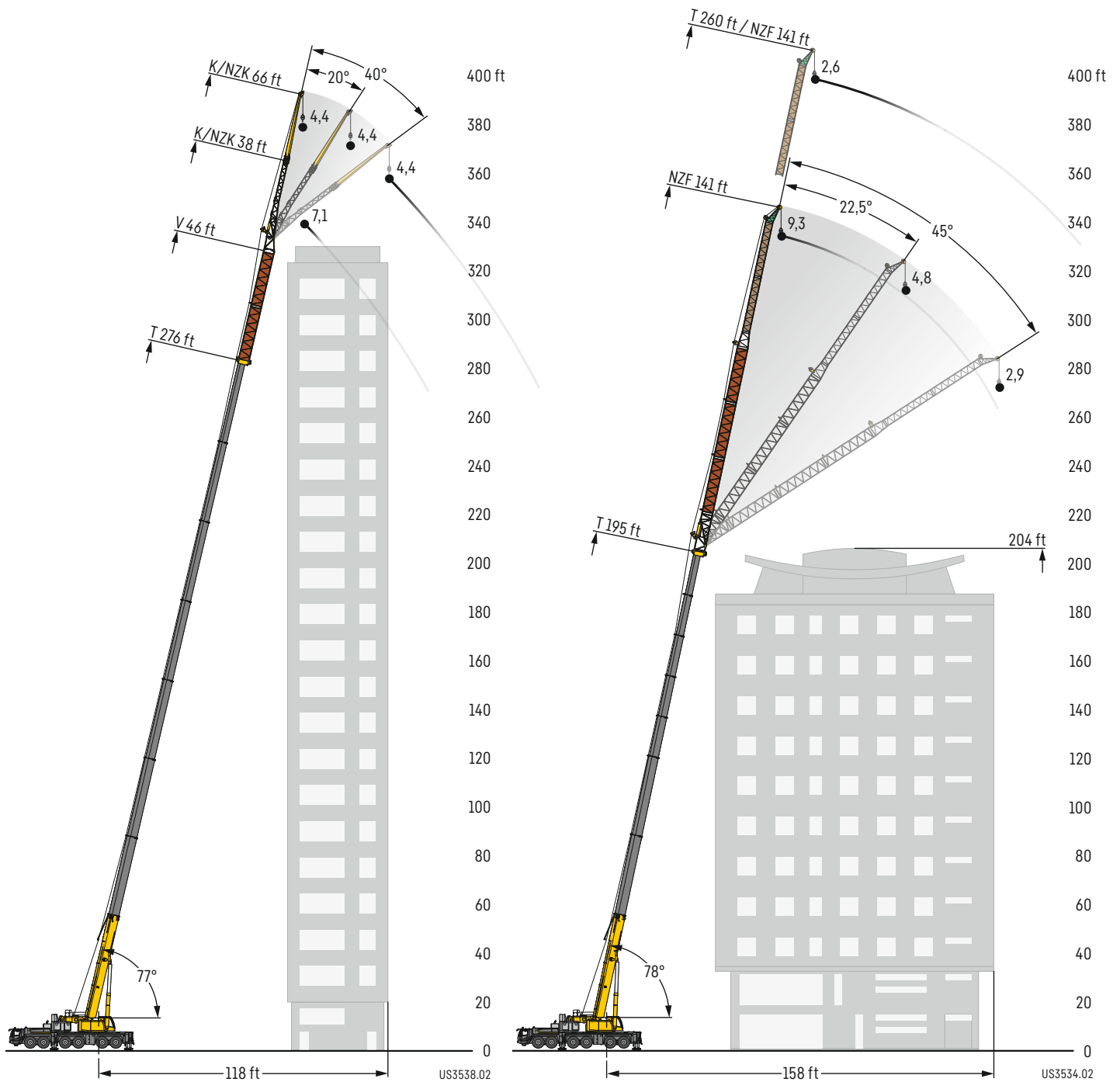

TS

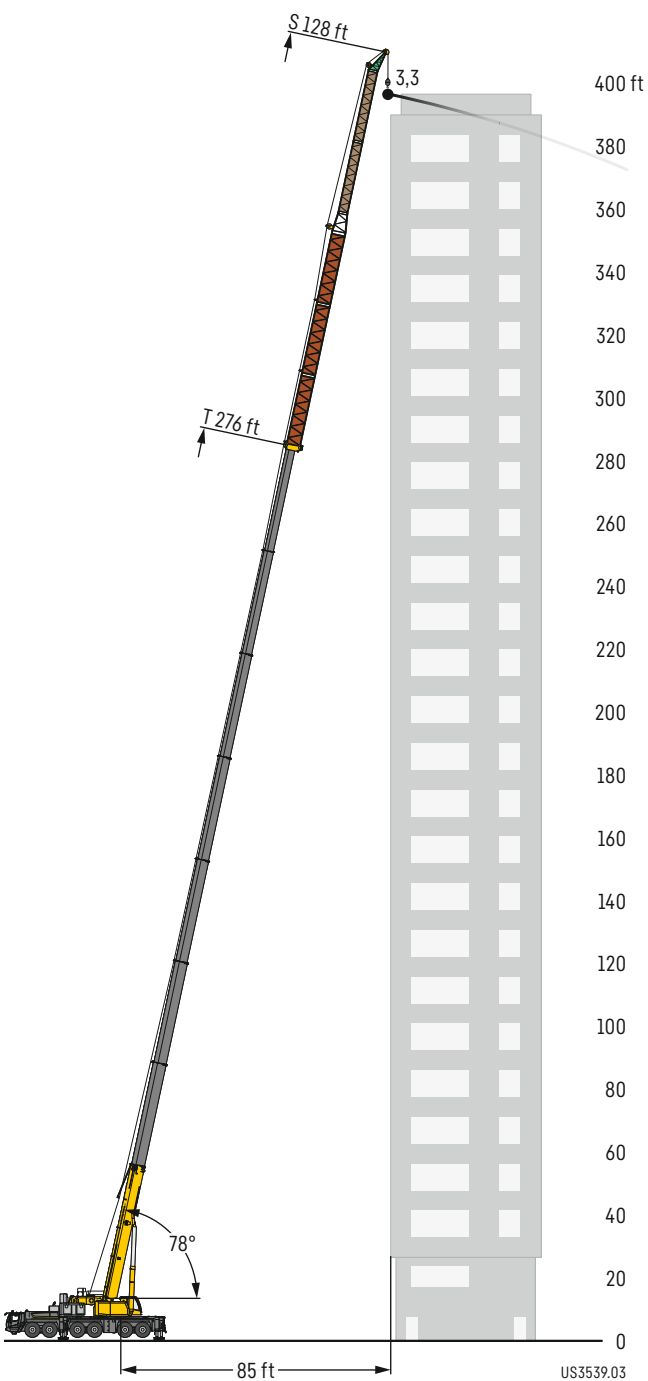

**TVK
TVNZK**

K	38 ft - 66 ft 0°; 20°; 40°
NZK	38 ft - 66 ft 0° - 40°
V	2 x 23 ft

66 ft double swing away jib. can technically be carried on crane

Double fléchette pliante de 66 ft avec maintien à demeure sur la grue

TNZF TS

NZF	26 ft - 141 ft 0° - 45°
S	13 ft - 128 ft 0°

Fixed jib contains strong jib

Fléchette fixe avec fléchette robuste

TS

S	13 ft - 128 ft 0°
----------	----------------------

Strong system for steep working positions

Système puissant pour les positions de travail les plus raides

23 ft Telescopic boom extension · Rallonge flèche télescopique

23 ft Swing away jib extension · Rallonge flechette pliante

Boom/jib combinations

Configurations de flèche

T Telescopic boom
Flèche télescopique

K/NZK Mechanically/hydraulically adjustable folding jib
Pointe pliante réglable mécaniquement/hydrauliquement

V Telescopic boom extension
Rallonge de flèche télescopique

S Strong jib
Fléchette particulièrement puissante

NZF Hydraulically adjustable fixed lattice jib
Fléchette treillis fixe réglable hydrauliquement



S3687

Lifting heights

Hauteurs de levage

T

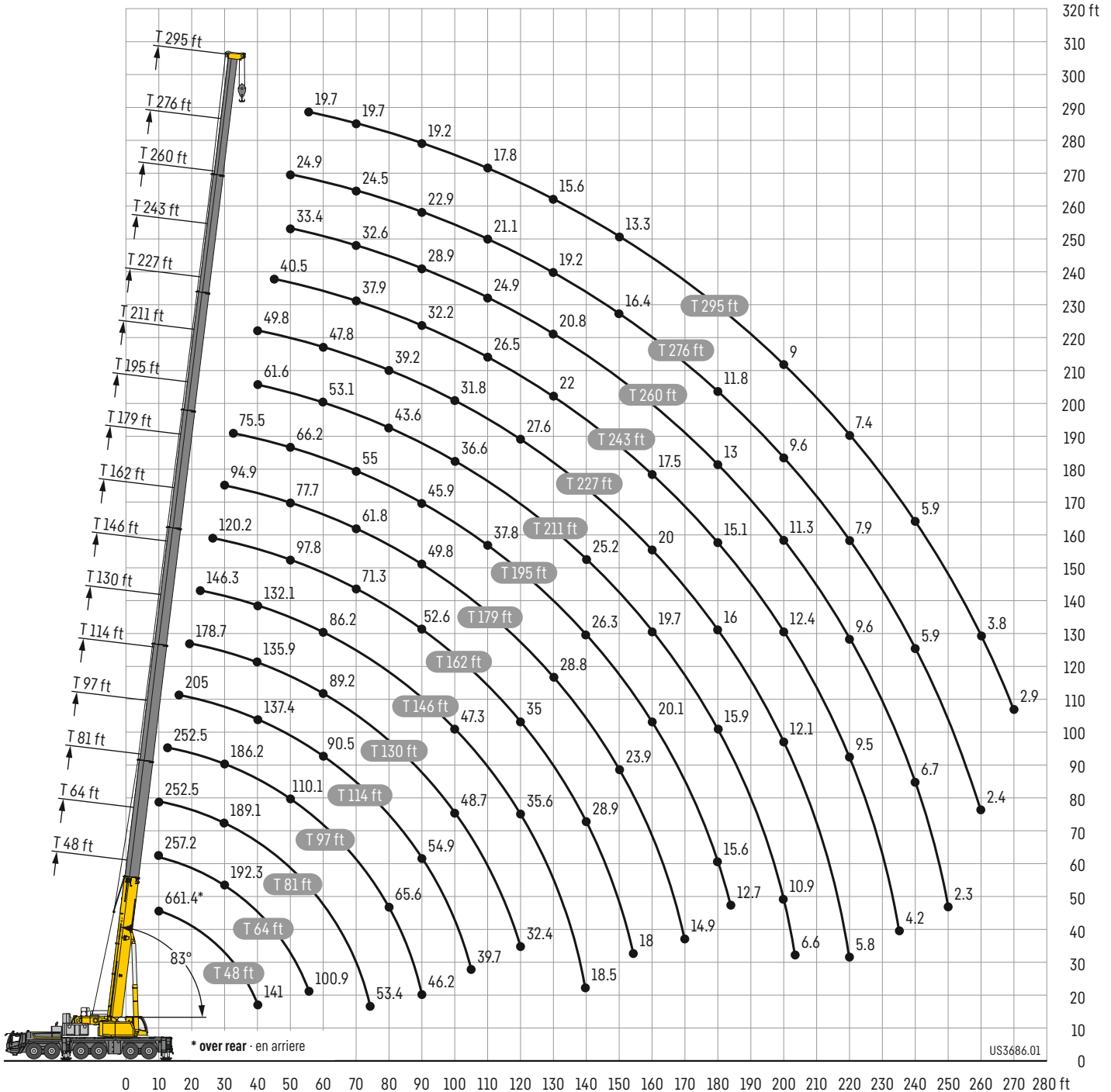

Lifting capacities

Forces de levage

T



	48 ft		64 ft	81 ft	97 ft	114 ft	130 ft	146 ft	162 ft	179 ft	195 ft	211 ft	227 ft	243 ft	260 ft	276 ft	295 ft	
	*																	
10	661.4	343.3	257.2	252.5														10
11	371.1	343.3	258.2	256.5														11
12	365.3	343.3	259.6	257.4														12
13	360.3	343.3	260.7	258.5	252.5													13
14	355.1	332.6	261.8	259.4	252.5													14
15	348.3	318.9	263	260.3	252.5													15
16	336.5	306.4	264.4	261.2	252.5	205												16
17	324.3	293.7	265.7	262.3	252.5	205												17
18	314.2	283.3	267.5	263.2	252.5	205												18
19	303.8	272.6	269.3	261.7	252.5	205	178.7											19
20	294.7	263.3	260.6	256.4	248.8	205	179.8											20
22	273.6	246	245	242.4	234.8	205	180.7	146.3										22
24	252.2	229.9	229.2	227.8	221.2	205	180.7	148.4										24
26	234	216.2	215.3	212.7	209.4	201.6	180.2	149.3	120.2									26
28	218.4	203.6	201.2	198.4	194.7	192	178	148.7	121.2									28
30	205.3	192.6	192.3	189.1	186.2	182.1	174.4	147	121.3	94.9								30
32	193.4	182.3	181	177.5	175.3	170.6	166.3	145.2	119.4	95.1								32
34	183.3	173.1	170.3	168.2	165	160.3	157	143.2	117.1	94.2	75.5							34
36	170.5	164.5	161.4	158.6	155.4	152.5	150	141.2	114.3	92.3	75.9							36
38	156.7	156.7	152.9	150.2	146.8	144.1	142.7	137.3	111.4	89.9	75.6	61.6						38
40	140.8	141	145.3	142.4	139.2	137.4	135.9	132.1	109	87.9	75	61.9	49.8					40
45			129.9	126.2	123.6	122.9	120.4	116.7	103	82.6	70.8	61.9	50.2	40.5				45
50			117.9	113	110.1	110.5	108.1	104.5	97.8	77.7	66.2	59.4	50.4	40.9	33.4	24.9		50
55			100.9	102.8	99.5	99.1	97.8	93.8	92.6	73.1	62.1	56.1	49.7	41.1	33.7	24.9	19.7	55
60				93.9	90.6	90.5	89.2	86.2	85.8	69.1	59.5	53.1	47.8	40.5	33.8	24.9	19.7	60
65				84.5	83.9	82.7	81.2	80.6	78.1	65.2	57.2	50	45.6	39.3	33.4	24.8	19.7	65
70				74.8	78.2	76.4	74.6	74.3	71.3	61.8	55	47.4	43.3	37.9	32.6	24.5	19.7	70
75				53.4	71.7	70.6	68.6	68.4	66.1	58.5	52.8	45.3	41.2	36.7	31.7	24.1	19.7	75
80					65.6	64.8	64.2	63.5	61.1	55.5	50.5	43.6	39.2	35.3	30.7	23.7	19.6	80
85					59.8	59.6	60.8	59	56.5	52.6	48.2	41.8	37.2	33.8	29.7	23.3	19.4	85
90					46.2	54.9	56.7	55	52.6	49.8	45.9	40	35.2	32.2	28.9	22.9	19.2	90
95						50.7	52.4	51.1	48.9	47	43.8	38.3	33.5	30.7	28	22.4	18.9	95
100						47.7	48.7	47.3	45.6	44.2	41.7	36.6	31.8	29.2	27	22	18.7	100
105						39.7	45.4	44	42.2	41.3	39.6	35	30.5	27.8	25.9	21.6	18.3	105
110							42.3	40.9	39.2	38.4	37.8	33.2	29.5	26.5	24.9	21.1	17.8	110
115							39.6	38.2	36.3	35.6	36.1	31.6	28.5	25.2	23.9	20.7	17.3	115
120							32.4	35.6	35	33.1	34.3	30.2	27.6	24	22.8	20.3	16.8	120
125								33.3	33.9	30.7	32.3	28.8	26.6	22.9	21.8	19.8	16.2	125
130								31.1	32.6	28.8	30.1	27.6	25.7	22	20.8	19.2	15.6	130
135								28.9	30.8	27.5	28.1	26.3	24.6	21.2	19.8	18.6	15	135
140									18.5	28.9	26.2	26.3	25.2	23.6	20.3	18.8	17.9	140
145										27.2	25	24.5	24	22.6	19.6	17.8	17.2	145
150										22.8	23.9	22.9	22.6	21.7	18.8	16.9	16.4	150
155										18	22.6	21.4	21.1	20.8	18.1	15.9	15.6	155
160											21.1	20.1	19.7	20	17.5	15.2	14.8	160
165											18.6	18.8	18.4	19.2	16.8	14.6	14	165
170										14.9	16.7	16.6	17.1	15.6	13.5	12.5	10.8	170
175											15.6	15.9	16	15.1	13	11.8	10.4	175
180												12.7	15.2	15	14.6	12.5	11.2	180
185													14.7	14	14.1	12.1	10.7	185
190													12.9	13	13.3	11.7	10.1	190
195														10.9	12.1	12.4	11.3	195
200														6.6	11.4	11.6	11	200
205															10.7	10.9	10.6	205
210															9.2	10.3	10.2	210
215																8.3	7.8	215
220															5.8	9.5	9.6	220
225																9	7.5	225
230																7.1	8.4	230
235																4.2	7.8	235
240																	6.7	240
245																	5	245
250																	2.3	250
255																	4.2	255
260																	2.4	260
265																		265
270																		270

* over rear · en arriere

Lifting capacities

Forces de levage

T

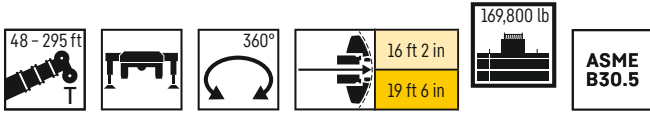

	48 ft	64 ft	81 ft	97 ft	114 ft	130 ft	146 ft	162 ft	179 ft	195 ft	211 ft	227 ft	243 ft	260 ft	276 ft	295 ft	
10	343.3	257.2	252.5														10
11	343.3	258.2	256.5														11
12	343.3	259.6	257.4														12
13	339.9	260.7	258.5	252.5													13
14	327.1	261.8	259.4	252.5													14
15	313.6	263	260.3	252.5													15
16	301.3	264.4	261.2	252.5	205												16
17	288.8	265.7	262.3	252.5	205												17
18	278.5	267.2	263.2	252.5	205												18
19	268	266.1	260.4	252.3	205	178.7											19
20	258.9	256.2	252.5	247	205	179.8											20
22	241.8	240.8	237	230.3	205	180.7	146.3										22
24	226	224	219.4	214.5	205	180.7	148.4										24
26	212.5	208	204.9	200.9	196	180.2	149.3	120.2									26
28	200	197.5	192.7	190.7	185.9	178	148.7	121.2									28
30	188.5	184.3	181.5	178.7	174.7	169.7	147	121.3	94.9								30
32	177.6	173.5	170.1	168.1	163.6	159.9	145.2	119.4	95.1								32
34	168.5	164.3	161.2	158.2	153.7	153	143.2	117.1	94.2	75.5							34
36	160.2	155.5	151.9	148.9	147.7	145.1	139.7	114.3	92.3	75.9							36
38	151.8	147.6	143.8	140.6	140.4	136.8	133.3	111.4	89.9	75.6	61.6						38
40	140.9	140.4	136.4	133.3	133.2	130.2	126.6	109	87.9	75	61.9	49.8					40
45		125.5	120.7	118.2	117.6	115.5	111.7	103	82.6	70.8	61.9	50.2	40.5				45
50		110.1	108	107	105.7	103.9	99.9	97.8	77.7	66.2	59.4	50.4	40.9	33.4	24.9		50
55		97.2	97.1	97.3	94.7	93.5	91.2	90.4	73.1	62.1	56.1	49.7	41.1	33.7	24.9	19.7	55
60			86.4	88.7	86.4	85.1	84.3	81.7	69.1	59.5	53.1	47.8	40.5	33.8	24.9	19.7	60
65			77.6	79.9	78.9	77.4	77.1	74	65.2	57.2	50	45.6	39.3	33.4	24.8	19.7	65
70			70	72.3	71.6	71.9	70.8	67.5	61.8	55	47.4	43.3	37.9	32.6	24.5	19.7	70
75			53.4	65.7	65	66.8	65.1	61.9	58.5	52.8	45.3	41.2	36.7	31.7	24.1	19.7	75
80				61.4	59.3	61.1	59.7	57.1	54.9	50.5	43.6	39.2	35.3	30.7	23.7	19.6	80
85				56.5	55.1	56	54.9	52.7	50.8	48.2	41.8	37.2	33.8	29.7	23.3	19.4	85
90				46.2	52.3	51.7	50.4	48.6	46.9	45.9	40	35.2	32.2	28.9	22.9	19.2	90
95					48.8	47.8	46.5	44.5	43.4	43.8	38.3	33.5	30.7	28	22.4	18.9	95
100					45.3	44.2	42.6	41.1	39.8	41.2	36.6	31.8	29.2	27	22	18.7	100
105					39.7	40.8	39.2	39.3	37.4	38.2	35	30.5	27.8	25.9	21.6	18.3	105
110						37.8	36.2	37.7	35.4	35.2	33.2	29.5	26.5	24.9	21.1	17.8	110
115						35.1	33.8	35.3	33.4	32.4	31.6	28.5	25.2	23.9	20.7	17.3	115
120						32.2	32.7	32.8	31.1	29.8	29.5	27.6	24	22.8	20.3	16.8	120
125							31.6	30.5	28.8	27.6	27.2	26.6	22.9	21.8	19.8	16.2	125
130							30.1	28.4	26.7	25.9	25.2	25.7	22	20.8	19.2	15.6	130
135							28.2	26.5	24.8	24.4	23.5	24.3	21.2	19.8	18.6	15	135
140							18.5	24.8	23.7	22.8	22.4	22.7	20.3	18.8	17.9	14.4	140
145								23.2	22.7	21.1	21.3	21.1	19.6	17.8	17.2	13.8	145
150								21.8	21.1	19.7	20.3	19.5	18.8	16.9	16.4	13.3	150
155								18	19.8	18.8	19.3	18	18.1	15.9	15.6	12.7	155
160									18.5	18.1	18.5	16.7	16.9	15.2	14.8	12.2	160
165									17.3	17.4	17.3	16	15.8	14.6	13.9	11.7	165
170									14.9	16.8	16.1	15.4	14.6	14	13	11.2	170
175										15.9	15	14.7	13.5	13.3	12.2	10.8	175
180										15.1	14	13.8	12.5	12.4	11.2	10.4	180
185										12.7	13.3	12.8	12	11.4	10.4	9.8	185
190											12.8	11.9	11.5	10.6	9.7	9.4	190
195											12.4	11.1	10.9	9.9	9	8.8	195
200											10.9	10.4	10.3	9.3	8.3	8.1	200
205											6.6	9.9	9.7	8.7	7.6	7.4	205
210												9.6	9.1	8.1	6.9	6.8	210
215												9.2	8.5	7.4	6.2	6.2	215
220												5.8	7.9	6.7	5.6	5.6	220
225													7.3	6.1	4.9	5	225
230													6.7	5.6	4.4	4.4	230
235													4.2	5.1	3.8	3.8	235
240														4.5	3.2	3.3	240
245														4.1	2.8	2.8	245
250														2.3	2.3	2.3	250

Lifting capacities

Forces de levage

T



	48 ft	64 ft	81 ft	97 ft	114 ft	130 ft	146 ft	162 ft	179 ft	195 ft	211 ft	227 ft	243 ft	260 ft	276 ft	295 ft							
10	343.3	257.2	252.5														10						
11	343.3	258.2	256.5														11						
12	343.3	259.6	257.4														12						
13	340.1	260.7	258.5	252.5													13						
14	327.5	261.8	259.4	252.5													14						
15	314	263	260.3	252.5													15						
16	301.7	264.4	261.2	252.5	205												16						
17	289.1	265.7	262.3	252.5	205												17						
18	278.8	267.2	263.2	252.5	205												18						
19	268.3	266.4	260.1	252.5	205	178.7											19						
20	259.2	256.5	252.5	246.8	205	179.8											20						
22	242.1	239.1	232.8	226.8	205	180.7	146.3										22						
24	226.2	220	216.7	210.9	203	180.7	148.4										24						
26	210.5	203.8	200.8	196.9	192.7	180.2	149.3	120.2									26						
28	196.4	193.6	190.8	187.1	182.5	177.1	148.7	121.2									28						
30	184.7	180.6	177.9	175.2	171.2	166.9	147	121.3	94.9								30						
32	173.9	171.3	166.8	164.7	160.3	158.4	145.2	119.4	95.1								32						
34	165	161.2	158	154.9	152.9	150.3	143.2	117.1	94.2	75.5							34						
36	156.1	152.3	148.8	145.9	145.4	142.3	138	114.3	92.3	75.9							36						
38	145.6	144.6	140.9	137.7	137.8	134.1	130.6	111.4	89.9	75.6	61.6						38						
40	136.2	137.4	133.5	130.5	130.6	127.5	124	109	87.9	75	61.9	49.8					40						
45		120.7	118.1	116.7	115.2	113.9	109.2	103	82.6	70.8	61.9	50.2	40.5				45						
50		105.1	104.9	105.6	103.5	101.7	97	96.2	77.7	66.2	59.4	50.4	40.9	33.4	24.9		50						
55		92.6	92.6	94.8	92.6	91.4	90.4	86.2	73.1	62.1	56.1	49.7	41.1	33.7	24.9	19.7	55						
60			82.3	84.7	84	82.7	81.6	77.9	69.1	59.5	53.1	47.8	40.5	33.8	24.9	19.7	60						
65			73.8	76.1	75.4	76.1	74.2	70.5	65.2	57.2	50	45.6	39.3	33.4	24.8	19.7	65						
70			68.4	69.4	68.1	70	67.6	64.2	61.6	55	47.4	43.3	37.9	32.6	24.5	19.7	70						
75			53.4	63.6	61.6	63.4	61.7	58.8	56.7	52.8	45.3	41.2	36.7	31.7	24.1	19.7	75						
80				57.4	58	57.1	55.6	53.7	51.6	50.3	43.6	39.2	35.3	30.7	23.7	19.6	80						
85				52.1	52.9	51.7	50.4	48.9	46.9	47.5	41.8	37.2	33.8	29.7	23.3	19.4	85						
90				46.2	48.2	47.2	45.7	44.4	44.1	43.5	40	35.2	32.2	28.9	22.9	19.2	90						
95					44.3	43.1	41.7	42.5	41.3	40	37.9	33.5	30.7	28	22.4	18.9	95						
100					40.7	39.6	38.1	40	38.4	37	35.3	31.8	29.2	27	22	18.7	100						
105					37.6	36.5	36.5	36.9	35.2	33.9	32.7	30.5	27.8	25.9	21.6	18.3	105						
110						33.7	35.1	34	32.3	31.7	30.1	29.5	26.5	24.9	21.1	17.8	110						
115						31.1	33	31.3	29.9	29.4	27.9	28	25	23.9	20.7	17.3	115						
120						30.2	30.7	29	28.3	27.1	26.8	26.3	23.8	22.8	20.3	16.8	120						
125							28.6	27	26.5	25	25.7	24.5	22.9	21.4	19.8	16.2	125						
130							26.7	25	24.5	23.4	24.2	22.9	21.9	20	19.1	15.6	130						
135							25	23.3	22.8	22.4	22.4	21.1	20.7	18.5	18.1	15	135						
140							18.5	21.7	21.1	21.4	21.3	19.7	19.2	17.7	17.1	14.4	140						
145								20.3	19.7	20.4	19.7	18.8	18	17	16	13.8	145						
150								19.6	18.2	19.1	18.2	17.6	16.7	16.4	14.9	13.3	150						
155								18	17	17.9	16.9	16.6	15.4	15.3	13.8	12.7	155						
160									16.2	17	15.8	15.5	14.7	14.1	12.8	11.8	160						
165									15.5	15.9	15.2	14.3	14	12.9	11.7	11.2	165						
170									14.9	14.8	14.5	13.2	13	11.8	10.4	10.4	170						
175										13.8	13.6	12.3	12	10.9	9.9	9.6	175						
180										12.9	12.7	11.8	11.1	10.1	9.1	8.8	180						
185										12.1	11.8	11.3	10.4	9.4	8.4	8	185						
190											11	10.8	9.7	8.7	7.7	7.3	190						
195											10.4	10.2	9	8.1	7	6.6	195						
200												9.8	9.6	8.4	7.4	6.2	200						
205													6.6	9	7.8	6.7	205						
210														8.4	7.2	6.1	210						
215														7.8	6.5	5.4	215						
220															5.8	4.8	3.7	220					
225																5.4	4.3	3.1	225				
230																	4.9	3.7	2.5	230			
235																		4.2	3.3	2.5	235		
240																				2.8	2.4	2.4	240
245																							245

Lifting capacities

Forces de levage

T

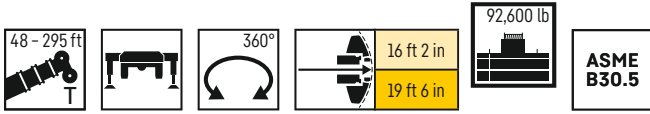

	48 ft	64 ft	81 ft	97 ft	114 ft	130 ft	146 ft	162 ft	179 ft	195 ft	211 ft	227 ft	243 ft	260 ft	276 ft	295 ft	
10	343.3	257.2	252.5														10
11	343.3	258.2	256.5														11
12	342.1	259.6	257.4														12
13	332.6	260.7	258.5	252.5													13
14	318	261.8	259.4	252.5													14
15	304.9	263	260.3	252.5													15
16	292.9	264.4	261.2	252.5	205												16
17	280.7	265.1	261.8	252.5	205												17
18	268.8	260.5	253.1	248.9	205												18
19	256.5	250.7	242.6	238	205	178.7											19
20	245.5	237.8	231.6	227.5	205	179.8											20
22	224.1	217.6	212.1	208.1	201.6	180.7	146.3										22
24	206.3	199.9	197.6	193.1	190.1	180.7	148.4										24
26	191.3	189.4	185.9	182.5	179.4	170	149.3	120.2									26
28	178.3	176	173.5	170.3	166.1	159.6	145.6	121.2									28
30	163.3	165.4	161.7	159.2	156.6	146.6	136.9	121.3	94.9								30
32	149.8	154.2	151.4	151.2	143.6	136.5	125.6	119.4	95.1								32
34	138.4	142.8	142.5	140.5	132.9	126.3	119.8	113.9	94.2	75.5							34
36	128.1	132.4	132.3	129.8	122.6	116.2	113.2	106	92.3	75.9							36
38	119.2	123.4	122.9	120.3	113.7	110.4	104.9	98.2	89.9	75.6	61.6						38
40	110.7	115.4	114.5	112.1	106.2	104.4	98.3	92.1	87	75	61.9	49.8					40
45		94.3	97.3	96.9	93.6	89.2	83.8	78.9	74.9	69.6	61.9	50.2	40.5				45
50		79.2	80.7	83.3	81.4	77.3	72.7	68.6	66.6	64.2	59.4	50.4	40.9	33.4	24.9		50
55		66.9	70.5	71.5	71.3	67.5	63.8	63.6	60.2	57	53.1	49	41.1	33.7	24.9	19.7	55
60			60.8	62.2	61.9	59.7	58.1	57	54.4	51.4	47.9	44.1	40.5	33.8	24.9	19.7	60
65			53	54.3	54.1	52.9	53.6	50.7	49.1	46	42.7	40.8	37.5	33.4	24.8	19.7	65
70			46.7	47.8	47.7	47.8	48.9	46.1	44	41.7	39.6	37.6	34.7	32.3	24.5	19.7	70
75			41.5	42.4	42.2	44.6	43.5	41.6	39.6	38.3	36.6	34.5	32.3	29.3	24.1	19.7	75
80				37.9	38.3	40.1	39	38.5	36.3	35.7	33.7	31.8	29.3	27.3	23.7	19.6	80
85				34.1	36.2	36	35	35	33.6	32.8	31.3	28.8	26.9	25.7	22.9	19.4	85
90				30.8	32.9	32.6	31.6	31.6	31.3	30	28.6	26.6	25.4	23.3	20.7	19.2	90
95					29.9	29.7	28.8	29.1	28.6	27.9	26.2	25.1	23.4	21.2	19.1	17.4	95
100					27.3	27	26.2	27.1	26.8	25.6	24.4	23.4	21.3	19.2	17.3	16.2	100
105					25.1	24.6	24.3	24.6	24.4	23.3	22.8	21.4	19.3	17.4	15.7	14.7	105
110						22.6	23.1	22.5	22.1	21.5	21.2	19.7	17.7	15.8	14	13.1	110
115						20.7	21.6	20.8	20.2	20.3	19.3	18.1	16.2	14.4	12.7	11.9	115
120						19.1	19.9	19	18.9	18.7	17.6	16.5	14.7	13	11.3	10.5	120
125							18.3	17.3	17.5	17	15.9	14.9	13.4	11.8	10.2	9.4	125
130							16.8	15.9	16.1	15.5	14.4	13.4	12.1	10.6	9	8.3	130
135							15.6	14.9	14.7	14.2	13	12.2	10.8	9.5	8	7.3	135
140							14.4	14.2	13.5	12.9	11.8	10.9	9.8	8.5	7	6.4	140
145								13.1	12.4	11.8	10.8	10	8.9	7.5	6	5.5	145
150								12.1	11.3	10.8	9.9	9.2	8.1	6.7	5.2	4.7	150
155								11.3	10.5	10	9.1	8.3	7.3	5.9	4.4	3.9	155
160									9.8	9.3	8.4	7.6	6.5	5.1	3.6	3.1	160
165									9.1	8.6	7.7	6.9	5.7	4.3	2.7	2.2	165
170									8.5	8	7	6.2	4.9	3.7			170
175										7.3	6.3	5.5	4.2	2.9			175
180										6.7	5.6	4.8	3.5				180
185										6.1	5	4.2	2.9				185
190											4.4	3.6					190
195											3.9	3					195
200											3.4	2.5					200
205											2.9						205

Lifting capacities

Forces de levage

T



	48 ft	64 ft	81 ft	97 ft	114 ft	130 ft	146 ft	162 ft	179 ft	195 ft	211 ft	227 ft	243 ft	260 ft	276 ft	295 ft	
10	343.3	257.2	252.5														10
11	343.3	258.2	256.5														11
12	338.8	259.6	257.4														12
13	326.2	260.7	258.5	252.5													13
14	311.9	261.8	259.4	252.5													14
15	294.9	263	260.3	252.5													15
16	278.8	262.5	261.2	252.5	205												16
17	263.1	255	247.9	240.8	205												17
18	250.6	244	238.3	227	203.2												18
19	238.4	232.9	225	210	193.3	176.3											19
20	228.1	220.7	215.3	200	182	169.7											20
22	207.1	199.6	190.3	178.9	163.3	156.8	139.3										22
24	185.6	184.5	170.6	159.2	149.5	141.9	130.4										24
26	167.2	163	152.6	144.9	135.1	127.6	117.5	107.8									26
28	148	143	136.5	130.3	123.8	115.4	106.4	99									28
30	131.1	127.3	122.4	118.5	111.7	105	96.8	89.2	83.9								30
32	115.7	115.1	112.9	108.3	102.5	95.2	88.6	84.9	79								32
34	101.6	104.9	102.9	99.2	93.7	87.7	84.3	79.9	74.6	69.9							34
36	89.8	95.8	94.6	91	86.1	81.1	79.4	74.9	70.7	65.7							36
38	80.1	87.5	86.9	84	79.6	75.8	74.9	69.5	65.9	61.6	57						38
40	71.9	79.3	80.2	78.1	74.1	72.8	69.4	65.1	61.8	57.8	53.4	47.6					40
45		62.9	66.6	65.3	63.2	62.7	59.4	57	53.4	50.5	46.9	43.4	38.6				45
50		51.2	54.9	55.6	56.4	54	51.2	49.5	47.3	45.2	42.9	39.1	35.4	31.6	24.9		50
55		42.3	45.9	47.6	48.8	47.1	44.9	44.2	42.4	39.9	37.3	34.6	31.9	29.3	24.8	19.7	55
60			38.8	42	42.7	41.1	41.3	38.9	37	35.7	33.7	31.5	28.4	25.4	22.6	19.7	60
65			33.2	36.3	36.9	36.5	36.6	34.5	33.7	32.5	30.1	27.9	25	22.3	20	17.8	65
70			28.6	31.5	32.2	33.2	32.6	30.6	30.4	29	26.8	24.5	22.1	19.7	17.3	15.8	70
75			24.9	27.7	28.4	29.6	29.1	28.5	27.2	25.9	23.9	21.8	19.4	17.1	14.9	13.7	75
80				24.4	25.1	26.3	25.7	25.7	24.4	23.2	21.2	19.4	17.2	14.9	12.9	11.8	80
85				21.6	22.2	23.3	22.9	22.7	21.9	20.9	18.9	17.3	15.1	13.1	11.1	10.1	85
90				19.2	19.7	20.6	20.2	20.1	19.5	18.7	16.9	15.4	13.2	11.4	9.5	8.6	90
95					17.5	18.4	17.9	17.8	17.2	16.5	15.2	13.7	11.7	9.8	8	7.1	95
100					15.5	16.4	15.9	15.8	15.2	14.6	13.3	12.1	10.2	8.4	6.7	5.9	100
105					13.8	14.6	14.1	14	13.4	12.8	11.6	10.6	8.8	7.1	5.5	4.6	105
110						13	12.5	12.4	11.8	11.3	10.3	9.4	7.6	5.9	4.1		110
115						11.6	11.1	11	10.5	10	9.1	8.1	6.4	4.7	2.9		115
120						10.5	10.1	10	9.4	9	8.1	7	5.3	3.5			120
125							9.1	9	8.5	8	7.1	6	4.2	2.3			125
130							8.3	8.2	7.6	7.2	6.2	5	3				130
135							7.5	7.4	6.8	6.4	5.3	4.1					135
140							6.8	6.6	6	5.6	4.5	3.1					140
145								5.9	5.2	4.8	3.7						145
150								5.2	4.5	4	2.8						150
155								4.6	3.8	3.3							155
160									3.2	2.5							160
165									2.5								165

Lifting heights

Hauteurs de levage

TK/TNZK

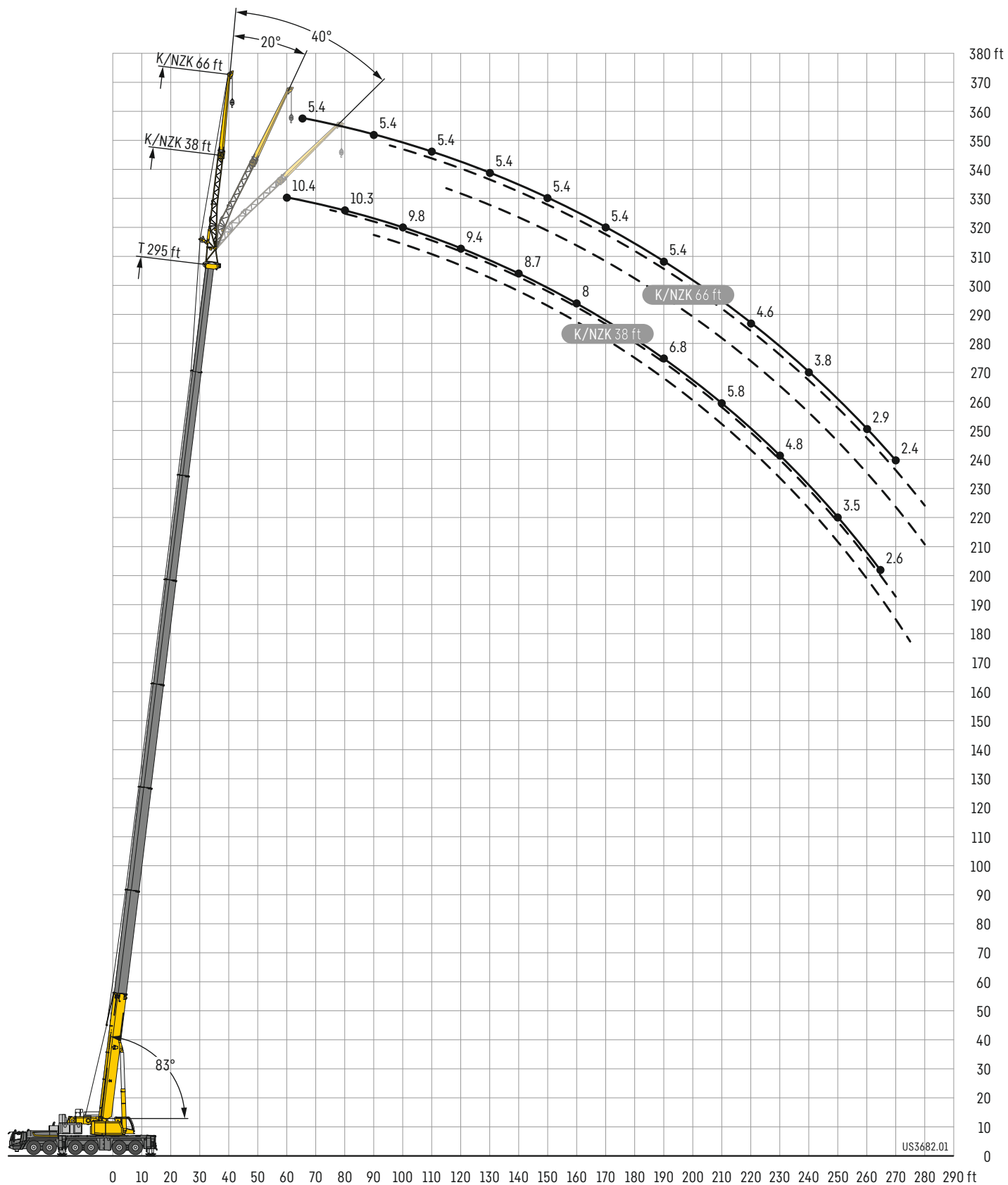

Lifting capacities

Forces de levage

TK/TNZK

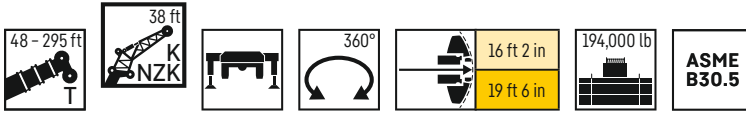

	48 ft			114 ft			130 ft			146 ft			162 ft			179 ft			195 ft			
	K/NZK 38 ft																					
	0°	20°	40°	0°	20°	40°	0°	20°	40°	0°	20°	40°	0°	20°	40°	0°	20°	40°	0°	20°	40°	
12	53.6																					12
13	53.6																					13
14	53.6																					14
15	53.6																					15
16	53.6			53.6																		16
17	53.6			53.6																		17
18	53.6			53.6																		18
19	53.6	44.3		53.6			53.6															19
20	53.6	43.5		53.6			53.6															20
22	53.6	41.9		53.6			53.6			53.6												22
24	53.6	39.9		53.6			53.6			53.6												24
26	52.5	37.8		53.6			53.6			53.6			47.6									26
28	49.6	36	25.1	53.6			53.6			53.6			47.2									28
30	46.7	34.3	24.3	53.6	40		53.6			53.6			46.8			42.6						30
32	43.5	32.8	23.6	53.6	39.3		53.6	39.5		53.2			46.4			42.4						32
34	40.4	31.4	22.9	53.6	38.4		53.6	38.8		52.5	38.5		46.1			42.1			38.2			34
36	37.3	29.9	22.2	53.4	37.4		53.5	38.1		51.7	38		45.6			41.8			37.9			36
38	34.8	28.8	21.7	52.7	36.3	23.9	52.7	37.3		51	37.4		45.1	35.1		41.4			37.6			38
40	32.5	27.6	21.2	51.5	35.4	23.5	51.8	36.4	23.8	50.2	36.8		44.6	34.6		41			37.3			40
45	27.7	25.2	19.9	48.1	33.2	22.6	49.1	34.2	22.9	48.3	34.9	23.2	43.1	33.4		39.9	32.2		36.6			45
50	24.1	23	18.9	44.4	31.1	21.8	46.2	32.3	22.1	46.3	33.1	22.4	41.6	31.8	22	38.8	31.2	22	35.8	29.9		50
55	21.3	21.3	18.1	40.9	29.3	21	43	30.6	21.4	43.9	31.4	21.7	40.1	30.3	21.4	37.7	30.1	21.4	35	29.2	21.4	55
60	18.9	19.8	17.4	37.3	27.7	20.4	40.1	29	20.8	41.5	29.9	21.1	38.7	29	20.8	36.7	28.9	20.8	34.2	28.4	20.8	60
65	16.9	18.6	17	34.1	26.3	19.7	37.1	27.6	20.2	38.9	28.6	20.5	36.9	27.8	20.3	35.6	27.8	20.3	33.4	27.5	20.4	65
70	15.3	17.6	16.7	30.9	25	19.1	34.4	26.3	19.6	36.4	27.4	20	34.9	26.7	19.8	34.4	26.6	19.9	32.6	26.5	19.9	70
75	13.8	16.8	16.6	28.5	23.8	18.7	31.9	25.1	19.1	34.1	26.1	19.5	33.2	25.7	19.4	32.8	25.7	19.5	31.9	25.6	19.5	75
80	12.6	16.6		26.4	22.7	18.2	29.3	24	18.6	31.9	25	19	31.3	24.8	19	31.4	24.9	19.1	30.8	24.8	19.1	80
85				24.4	21.8	17.8	27.4	23	18.2	29.7	24.1	18.6	29.6	23.9	18.6	29.9	24.1	18.7	29.6	24.1	18.7	85
90				22.7	21	17.5	25.5	22.1	17.9	27.9	23.2	18.3	28	23.1	18.3	28.6	23.3	18.4	28.6	23.4	18.4	90
95				21.2	20.2	17.2	23.8	21.4	17.6	26.2	22.3	17.9	26.4	22.4	17.9	27.2	22.6	18.1	27.4	22.7	18.2	95
100				19.9	19.5	17	22.4	20.6	17.3	24.6	21.6	17.6	25	21.7	17.7	25.9	22	17.8	26.3	22.1	17.9	100
105				18.6	18.9	16.8	21	19.9	17	23.2	20.9	17.4	23.7	21.1	17.4	24.6	21.4	17.6	25.1	21.5	17.7	105
110				17.5	18.3	16.7	19.8	19.3	16.9	21.9	20.3	17.1	22.5	20.5	17.2	23.4	20.8	17.3	24.1	21	17.4	110
115				16.6	17.8	16.6	18.7	18.7	16.7	20.7	19.7	16.9	21.5	19.9	17	22.4	20.3	17.1	23.1	20.4	17.2	115
120				15.7	17.3	16.6	17.8	18.3	16.6	19.6	19.1	16.8	20.4	19.4	16.8	21.4	19.8	16.9	22.1	20	17	120
125				14.9	16.9	16.6	16.8	17.8	16.5	18.7	18.7	16.6	19.5	18.9	16.7	20.4	19.3	16.7	21.2	19.5	16.8	125
130				14.1	16.7	16.3	16	17.4	16.5	17.8	18.2	16.6	18.6	18.5	16.6	19.6	18.9	16.6	20.4	19.1	16.7	130
135				13.5	16.4	10.7	15.3	17	16.5	17	17.8	16.5	17.9	18.1	16.5	18.8	18.5	16.5	19.6	18.7	16.5	135
140				12.9	16.4	6.1	14.6	16.8	16.5	16.2	17.4	16.5	17.1	17.7	16.4	18.1	18.1	16.4	18.8	18.3	16.4	140
145				12.3			13.9	16.5	15.3	15.5	17.1	16.5	16.4	17.4	16.4	17.4	17.8	16.4	18	18	16.4	145
150							13.3	16.4	10	14.9	16.8	16.5	15.8	17.1	16.4	16.8	17.5	16.4	17.2	17.5	16.3	150
155							12.9	16.4	6.1	14.3	16.6	16.4	15.2	16.9	16.4	16.1	17.2	16.4	16.4	16.8	16	155
160							12.3	14.4		13.7	16.4	14.2	14.7	16.7	16.4	15.6	16.9	16.4	15.8	16	15.7	160
165										13.2	16.4	9.3	14.2	16.5	16.4	15.1	16.7	16.4	15.4	15.2	15.2	165
170										12.7	16.4	6.2	13.7	16.4	15.2	14.6	16.6	16.4	14.9	14.7	14.7	170
175										12.2	13.3		13.3	16.3	11.4	14.1	16.4	16.3	14.5	14.4	14.5	175
180													12.9	16.3	8.3	13.7	15.4	15.6	14.1	14.1	14.2	180
185													12.4	13.9	6.1	13.4	14.3	13.9	13.8	13.8	14.1	185
190													10.9	12.2		12.8	13.3	10.2	13.4	13.5	13.9	190
195																12.5	13.2	8.2	12.7	13.1	13.4	195
200																11.3	12.2	6.1	11.9	12.3	11.7	200
205																9	9.9		11.1	11.5	9.7	205
210																6.5			10.3	10.7	8.1	210
215																			9.2	9.6	6.2	215
220																			8.3	8.8	2.3	220
225																			6.3	6.5		225

Lifting capacities

Forces de levage

TK/TNZK

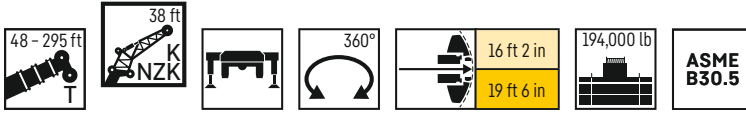

	211 ft			227 ft			243 ft			260 ft			276 ft			292 ft			295 ft			
	K/NZK 38 ft																					
	0°	20°	40°	0°	20°	40°	0°	20°	40°	0°	20°	40°	0°	20°	40°	0°	20°	40°	0°	20°	40°*	
36	25.4																					36
38	31.5																					38
40	31.3			25.7																		40
45	30.9			25.6			21.7															45
50	30.4			25.5			21.6			17												50
55	29.9	26.4		25.3	23.7		21.5			17			13.8									55
60	29.5	25.9	20.3	25.1	23.4		21.4	20.6		17			13.8			10.8				10.4		60
65	29	25.4	19.8	24.9	23.1	20.2	21.2	20.4		17	16.7		13.8			10.8				10.4		65
70	28.5	24.8	19.4	24.7	22.7	19.8	21.1	20.2		16.9	16.5		13.8	13.2		10.8				10.4		70
75	28	24.1	19	24.4	22.3	19.5	21	20	18.6	16.7	16.2		13.6	13		10.8	10.4			10.4	10.2	75
80	27.3	23.4	18.7	24.1	22.1	19.2	20.9	19.8	18.4	16.5	15.9	15.7	13.4	12.9		10.6	10.3			10.3	10.1	80
85	26.5	22.8	18.3	23.7	21.7	18.9	20.7	19.5	18.1	16.2	15.7	15.3	13.1	12.8	13.1	10.4	10.2	10.4		10.2	10	85
90	25.7	22.2	18.1	23.1	21.1	18.6	20.5	19.3	17.9	16	15.3	14.9	12.9	12.7	12.9	10.2	10.2	10.4	10	9.9	10.1	90
95	24.8	21.7	17.8	22.5	20.6	18.4	20.2	19	17.7	15.7	15	14.6	12.6	12.5	12.6	10.1	10.1	10.3	9.9	9.8	10.1	95
100	23.9	21.1	17.6	21.9	20.1	18.1	19.7	18.5	17.5	15.3	14.6	14.2	12.4	12.2	12.2	10	10	10.3	9.8	9.8	10	100
105	23.1	20.6	17.4	21.3	19.6	17.9	19.2	18.1	17.4	15.1	14.2	13.8	12	11.9	11.9	9.9	10	10.1	9.7	9.8	10	105
110	22.3	20.1	17.2	20.7	19.1	17.7	18.7	17.7	17.1	14.7	13.9	13.5	11.7	11.5	11.6	9.8	9.8	9.9	9.6	9.7	9.8	110
115	21.6	19.6	17	20.1	18.6	17.5	18.1	17.3	16.8	14.3	13.5	13.1	11.4	11.2	11.3	9.7	9.6	9.7	9.5	9.5	9.6	115
120	20.9	19	16.8	19.6	18.1	17.3	17.5	17	16.5	14	13.2	12.8	11.2	11	11	9.5	9.5	9.6	9.4	9.3	9.4	120
125	20.3	18.5	16.7	19	17.7	17	17	16.6	16.1	13.6	12.8	12.5	10.9	10.7	10.8	9.3	9.3	9.4	9.2	9.2	9.3	125
130	19.7	18	16.5	18.4	17.2	16.7	16.4	16.2	15.8	13.3	12.6	12.3	10.7	10.5	10.6	9.1	9.1	9.2	9	9	9.1	130
135	19	17.6	16.4	17.8	16.9	16.3	15.9	15.8	15.5	12.9	12.3	12	10.4	10.3	10.3	9	8.9	9	8.9	8.8	8.9	135
140	18.3	17.1	16.2	17.2	16.5	16	15.3	15.3	15.2	12.6	12	11.8	10.2	10	10.1	8.8	8.7	8.8	8.7	8.6	8.7	140
145	17.6	16.6	16.1	16.6	16.1	15.7	14.7	14.9	14.9	12.3	11.7	11.5	10	9.8	9.9	8.6	8.5	8.6	8.5	8.4	8.5	145
150	17	16.2	15.9	15.9	15.7	15.4	14.2	14.4	14.6	12	11.4	11.3	9.8	9.6	9.7	8.4	8.4	8.4	8.3	8.3	8.4	150
155	16.5	15.9	15.6	15	15.3	15.2	13.6	13.9	14.2	11.7	11.2	11.1	9.5	9.4	9.5	8.2	8.2	8.3	8.2	8.1	8.2	155
160	16	15.5	15.3	14.2	14.7	14.7	13	13.4	13.7	11.4	11	10.9	9.3	9.2	9.3	8.1	8	8.1	8	7.9	8	160
165	15.6	14.9	14.9	13.3	14	14.1	12.4	12.8	13.1	11.1	10.9	10.8	9.1	9	9.1	7.9	7.8	7.9	7.8	7.8	7.9	165
170	15.2	14.6	14.6	12.6	13.2	13.4	11.8	12.3	12.6	10.8	10.7	10.6	8.9	8.8	8.9	7.7	7.7	7.8	7.7	7.6	7.7	170
175	14.7	14.4	14.4	12.2	12.5	12.8	11.1	11.7	12	10.4	10.5	10.5	8.8	8.7	8.8	7.5	7.5	7.6	7.5	7.5	7.6	175
180	14.2	14	14.1	11.8	11.9	12.1	10.5	11	11.4	10	10.3	10.3	8.6	8.5	8.6	7.3	7.4	7.4	7.3	7.3	7.4	180
185	13.7	13.6	13.8	11.3	11.5	11.7	10.1	10.4	10.8	9.7	9.9	10.1	8.4	8.3	8.4	7.1	7.2	7.3	7	7.1	7.3	185
190	13.1	13.3	13.5	11	11.1	11.3	9.8	9.9	10.2	9.2	9.6	9.7	8.2	8.1	8.2	6.8	7	7.1	6.8	6.9	7.1	190
195	12.2	12.7	13.1	10.7	10.8	10.9	9.5	9.6	9.8	8.8	9.2	9.4	8	8	8.1	6.6	6.8	6.9	6.6	6.7	6.9	195
200	11.3	11.8	12.1	10.3	10.4	10.6	9.2	9.3	9.5	8.5	8.8	9	7.8	7.8	7.9	6.4	6.6	6.7	6.3	6.5	6.7	200
205	10.6	11	11.2	10.1	10.1	10.3	9	9.1	9.2	8	8.4	8.6	7.6	7.6	7.8	6.1	6.4	6.5	6.1	6.3	6.5	205
210	9.9	10.3	10.4	9.8	9.9	10	8.7	8.8	9	7.6	8	8.2	7.3	7.5	7.6	5.9	6.1	6.3	5.8	6.1	6.3	210
215	9.3	9.6	9.7	9.6	9.6	9.8	8.5	8.5	8.7	7.3	7.6	7.8	6.9	7.2	7.4	5.6	5.9	6	5.6	5.8	6	215
220	9.1	9.2	8.8	9.2	9.4	9.6	8.2	8.3	8.4	7.1	7.2	7.4	6.5	6.9	7.1	5.4	5.6	5.8	5.3	5.6	5.8	220
225	8.7	8.9	7.4	8.6	9	9.1	8	8	8.2	6.9	7	7.1	6.1	6.5	6.7	5.1	5.4	5.5	5.1	5.3	5.5	225
230	8	8.4	5.9	7.9	8.3	8.3	7.7	7.8	8	6.7	6.8	6.9	5.7	6.2	6.3	4.9	5.1	5.3	4.8	5.1	5.2	230
235	6.7	7	4.5	7.3	7.6	7.6	7.2	7.5	7.7	6.5	6.6	6.6	5.4	5.8	5.9	4.6	4.9	5	4.5	4.8	4.9	235
240	4.9	5.2		6.9	7	6.9	6.7	7	7.1	6.3	6.4	6.4	5	5.4	5.5	4.4	4.6	4.8	4.2	4.4	4.6	240
245				6.3	6.7	5.8	6.4	6.6	6.8	6.1	6.2	6.3	4.6	5	5.1	4.1	4.4	4.5	3.8	4.1	4.3	245
250				5.4	5.6	4.5	5.8	6.1	6.2	5.7	5.9	6	4.2	4.6	4.7	3.9	4.1	4.2	3.5	3.8	3.9	250
255				3.5	4.2		5.5	5.6	5.6	5.2	5.5	5.6	3.7	4.2	4.3	3.5	3.8	3.9	3.2	3.5	3.6	255
260							5.2	5.4	5.3	4.7	5	5.1	3.3	3.7	3.8	3.2	3.5	3.6	2.9	3.2	3.3	260
265							3.6	4.4	3.6	4.2	4.5	4.5	2.8	3.2	3.3	2.8	3.1	3.2	2.6	2.8	2.9	265
270										3.8	4	4	2.3	2.7	2.8	2.4	2.8	2.8		2.5	2.6	270
275										2.8	3.4	3.2			2.2	2.2	2.5				2.2	275

*only possible in TNZK mode · uniquement possible en cas de fonctionnement de la pointe pliante hydraulique de la flèche télescopique (TNZK)

Lifting capacities

Forces de levage

TK/TNZK

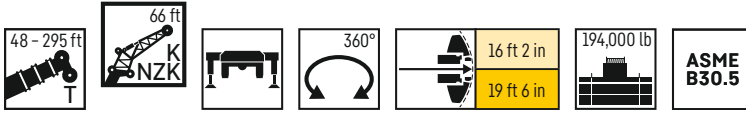

	48 ft			114 ft			130 ft			146 ft			162 ft			179 ft			195 ft				
	K/NZK 66 ft																						
	0°	20°	40°	0°	20°	40°	0°	20°	40°	0°	20°	40°	0°	20°	40°	0°	20°	40°	0°	20°	40°		
22	20.8			19.6			19.1															22	
24	20.8			19.9			19.6			19												24	
26	20.4			19.9			19.6			19.1												26	
28	20			19.9			19.6			19.2			17.7									28	
30	19.5			19.9			19.6			19.2			17.7			17						30	
32	18.9			19.8			19.6			19.2			17.7			17						32	
34	18.3	14.2		19.7			19.5			19.1			17.7			17				16.1		34	
36	17.7	13.9		19.6			19.4			19			17.6			16.9				16.1		36	
38	17.2	13.5		19.4			19.3			18.9			17.6			16.9				16.1		38	
40	16.7	13.2		19.2			19.1			18.8			17.5			16.8				16.1		40	
45	15.4	12.3		18.6	13.5		18.7	13.6		18.5			17.3			16.6				15.9		45	
50	14.3	11.5	9.6	17.8	12.9		18.1	13		18.1	13.1		17			16.4				15.7		50	
55	13.1	10.9	9.3	17	12.3		17.4	12.5		17.5	12.6		16.6	12.2		16.2	12.1			15.5		55	
60	11.7	10.3	8.9	16.2	11.7	9.3	16.7	12		16.9	12.1		16.2	11.8		15.8	11.7			15.3	11.5	60	
65	10.7	9.9	8.6	15.4	11.3	9.1	15.9	11.5	9.1	16.3	11.6	9.2	15.7	11.4		15.4	11.3			15	11.2	65	
70	9.8	9.5	8.4	14.7	10.9	8.9	15.3	11.1	8.9	15.7	11.2	9	15.2	11	8.9	15	11			14.6	10.9	70	
75	9	9.1	8.2	14	10.6	8.7	14.6	10.8	8.8	15	10.9	8.8	14.6	10.7	8.7	14.5	10.7	8.7		14.2	10.6	8.6	75
80	8.4	8.8	8	13.3	10.2	8.5	14	10.4	8.6	14.4	10.6	8.7	14.1	10.5	8.6	14	10.4	8.5		13.7	10.4	8.5	80
85	7.8	8.5	7.9	12.7	9.9	8.4	13.4	10.2	8.5	13.8	10.3	8.5	13.5	10.2	8.4	13.5	10.2	8.4		13.3	10.2	8.4	85
90	7.3	8.2	7.8	11.9	9.6	8.2	12.8	9.9	8.3	13.3	10	8.4	13	10	8.3	13.1	10	8.3		12.9	10	8.2	90
95	6.9	8	7.8	11.2	9.4	8.1	12.1	9.6	8.2	12.8	9.8	8.2	12.5	9.7	8.2	12.6	9.8	8.2		12.5	9.8	8.2	95
100	6.4	7.8	7.8	10.5	9.2	8	11.5	9.4	8.1	12.2	9.6	8.1	12.1	9.5	8.1	12.2	9.6	8.1		12.1	9.6	8.1	100
105	6.1	7.7		10	9	7.9	10.9	9.2	8	11.7	9.4	8	11.7	9.3	8	11.8	9.4	8		11.8	9.4	8	105
110				9.5	8.8	7.8	10.3	9	7.9	11.1	9.2	7.9	11.3	9.1	7.9	11.4	9.2	7.9		11.4	9.2	7.9	110
115				9	8.6	7.8	9.8	8.8	7.8	10.6	9	7.9	10.8	9	7.8	11.1	9	7.8		11.1	9	7.8	115
120				8.6	8.4	7.7	9.4	8.6	7.7	10.1	8.8	7.8	10.4	8.8	7.7	10.7	8.8	7.7		10.8	8.9	7.7	120
125				8.2	8.2	7.7	9	8.5	7.7	9.7	8.6	7.7	10	8.7	7.7	10.4	8.7	7.7		10.5	8.7	7.7	125
130				7.9	8.1	7.6	8.6	8.3	7.6	9.3	8.5	7.7	9.6	8.5	7.6	10	8.6	7.6		10.2	8.6	7.6	130
135				7.5	8	7.6	8.2	8.2	7.6	8.9	8.3	7.6	9.3	8.4	7.6	9.7	8.4	7.6		9.9	8.5	7.6	135
140				7.3	7.9	7.6	7.9	8	7.6	8.6	8.2	7.6	8.9	8.2	7.6	9.3	8.3	7.5		9.6	8.4	7.5	140
145				7	7.8	7.6	7.6	7.9	7.6	8.3	8.1	7.6	8.6	8.1	7.5	9	8.2	7.5		9.3	8.2	7.5	145
150				6.7	7.7	7.6	7.3	7.8	7.6	8	8	7.5	8.3	8	7.5	8.7	8.1	7.5		9	8.1	7.4	150
155				6.5	7.7	7.6	7.1	7.8	7.6	7.7	7.9	7.5	8	7.9	7.5	8.4	8	7.5		8.7	8	7.4	155
160				6.3	7.7	7.6	6.9	7.7	7.6	7.4	7.8	7.5	7.8	7.8	7.5	8.1	7.9	7.4		8.5	7.9	7.4	160
165				6.1	7.7		6.6	7.7	7.6	7.2	7.7	7.5	7.5	7.8	7.5	7.9	7.8	7.4		8.2	7.8	7.4	165
170				5.9	7.7		6.4	7.6	7.6	6.9	7.7	7.5	7.3	7.7	7.5	7.7	7.7	7.4		8	7.7	7.4	170
175							6.3	7.6	7.6	6.7	7.6	7.5	7.1	7.6	7.5	7.4	7.6	7.4		7.8	7.7	7.4	175
180							6.1	7.6		6.5	7.6	7.5	6.9	7.6	7.5	7.2	7.6	7.4		7.6	7.6	7.4	180
185							5.9	7.6		6.4	7.6	7.5	6.7	7.5	7.5	7.1	7.5	7.4		7.4	7.6	7.4	185
190							5.8			6.2	7.6	7.5	6.6	7.5	7.5	6.9	7.5	7.4		7.2	7.5	7.4	190
195										6	7.6		6.4	7.5	7.5	6.7	7.5	7.4		7	7.5	7.4	195
200										5.9	7.6		6.2	7.5	7.5	6.6	7.5	7.4		6.8	7.4	7.4	200
205										5.8			6.1	7.5	7.5	6.4	7.5	7.4		6.7	7.4	7.4	205
210													6	7.5		6.3	7.5	7.4		6.5	7.4	7.4	210
215													5.9	7.5		6.2	7.5	7.4		6.4	7.4	7.4	215
220													5.8			6	7.5	7.4		6.3	7.4	7.4	220
225																5.9	7.5	7		6.2	7.4	7.4	225
230																5.8	7.5			6.1	7.4	7.4	230
235																5.8				6	7.4	7.4	235
240																				5.8	7.4	6.9	240
245																				5.8	6.9		245
250																				5.3	5.4		250

Lifting capacities

Forces de levage

TK/TNZK

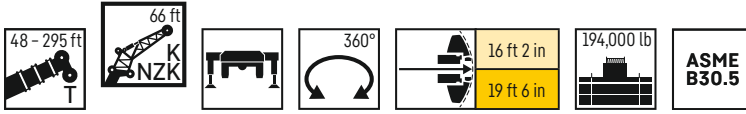

	211 ft			227 ft			243 ft			260 ft			276 ft			292 ft			295 ft				
	K/NZK 66 ft																						
	0°	20°	40°	0°	20°	40°	0°	20°	40°	0°	20°	40°	0°	20°	40°	0°	20°	40°	0°	20°*	40°*		
38	14.5																					38	
40	14.4																					40	
45	14.3			13.1																		45	
50	14.2			13			11.7															50	
55	14.1			12.9			11.5			10.1												55	
60	13.9			12.8			11.4			10			8.6									60	
65	13.7	10.7		12.6			11.3			10			8.6			5.7				5.4		65	
70	13.4	10.5		12.4	10.2		11.2			9.9			8.6			5.7				5.4		70	
75	13.1	10.3		12.2	10		11.1	9.6		9.8			8.6			5.7				5.4		75	
80	12.7	10.1	8.3	11.9	9.8		10.9	9.4		9.8	8.8		8.5			5.7				5.4		80	
85	12.4	9.8	8.2	11.6	9.6	8.1	10.8	9.2		9.7	8.7		8.4	7.9		5.7				5.4		85	
90	12.1	9.6	8.1	11.4	9.4	8	10.7	9.1	7.8	9.6	8.6		8.3	7.9		5.7				5.4		90	
95	11.8	9.5	8	11.2	9.2	7.9	10.5	8.9	7.7	9.5	8.5		8.2	7.9		5.7	6.6			5.4	6.4	95	
100	11.4	9.3	7.9	10.9	9.1	7.8	10.3	8.8	7.6	9.4	8.4	7.4	8.1	7.8		5.7	6.5			5.4	6.4	100	
105	11.2	9.1	7.9	10.7	8.9	7.7	10.1	8.7	7.6	9.3	8.2	7.4	8	7.8	7.1	5.7	6.5			5.4	6.4	105	
110	10.9	9	7.8	10.5	8.8	7.7	10	8.5	7.5	9.2	8.1	7.3	7.9	7.7	7.1	5.7	6.5			5.4	6.4	110	
115	10.7	8.8	7.7	10.3	8.7	7.6	9.8	8.4	7.5	9.1	8	7.3	7.9	7.6	7	5.7	6.5	6.6		5.4	6.4	6.4	115
120	10.4	8.7	7.6	10.1	8.5	7.6	9.7	8.3	7.4	9	8	7.2	7.8	7.5	7	5.7	6.5	6.6		5.4	6.4	6.4	120
125	10.2	8.5	7.6	9.9	8.4	7.5	9.5	8.2	7.4	8.9	7.8	7.2	7.8	7.5	7	5.7	6.5	6.6		5.4	6.4	6.4	125
130	10	8.4	7.5	9.7	8.3	7.4	9.3	8.1	7.3	8.8	7.8	7.1	7.7	7.4	6.9	5.7	6.5	6.6		5.4	6.4	6.4	130
135	9.7	8.3	7.5	9.5	8.2	7.4	9.2	8	7.3	8.7	7.7	7.1	7.7	7.4	6.9	5.7	6.5	6.6		5.4	6.3	6.4	135
140	9.5	8.2	7.4	9.3	8.1	7.4	9.1	7.9	7.2	8.6	7.6	7.1	7.7	7.3	6.9	5.7	6.5	6.6		5.4	6.3	6.4	140
145	9.2	8.1	7.4	9.1	8	7.3	8.9	7.8	7.2	8.4	7.5	7	7.7	7.2	6.9	5.7	6.5	6.6		5.4	6.3	6.4	145
150	9	8	7.4	8.9	7.9	7.3	8.8	7.8	7.2	8.3	7.5	7	7.6	7.2	6.9	5.7	6.5	6.6		5.4	6.3	6.4	150
155	8.8	7.9	7.3	8.7	7.8	7.3	8.6	7.7	7.2	8.2	7.4	7	7.6	7.1	6.9	5.7	6.5	6.6		5.4	6.3	6.4	155
160	8.5	7.8	7.3	8.5	7.7	7.2	8.4	7.6	7.1	8.1	7.4	7	7.5	7.1	6.8	5.7	6.4	6.6		5.4	6.3	6.4	160
165	8.3	7.7	7.3	8.3	7.6	7.2	8.2	7.5	7.1	8	7.3	7	7.3	7	6.8	5.7	6.4	6.5		5.4	6.3	6.4	165
170	8.1	7.7	7.3	8.1	7.6	7.2	8.1	7.5	7.1	7.8	7.3	7	7.2	7	6.8	5.7	6.3	6.4		5.4	6.2	6.4	170
175	7.9	7.6	7.3	7.9	7.5	7.2	7.9	7.4	7.1	7.7	7.2	7	7.1	6.9	6.8	5.7	6.2	6.3		5.4	6.1	6.3	175
180	7.6	7.5	7.3	7.7	7.5	7.2	7.7	7.4	7.1	7.5	7.2	7	6.9	6.8	6.8	5.7	6	6.2		5.4	6	6.1	180
185	7.5	7.5	7.3	7.6	7.4	7.2	7.6	7.3	7.1	7.4	7.1	7	6.8	6.7	6.8	5.7	5.9	6.1		5.4	5.9	6	185
190	7.3	7.4	7.3	7.4	7.4	7.2	7.4	7.2	7.1	7.2	7.1	7	6.7	6.7	6.7	5.6	5.8	5.9		5.4	5.7	5.9	190
195	7.1	7.4	7.3	7.3	7.3	7.2	7.3	7.2	7.1	7.1	7.1	7	6.5	6.5	6.6	5.6	5.7	5.8		5.4	5.6	5.8	195
200	7	7.4	7.3	7.1	7.3	7.2	7.1	7.2	7.1	7	7	7	6.4	6.4	6.5	5.4	5.5	5.7		5.3	5.5	5.7	200
205	6.8	7.3	7.3	6.9	7.3	7.2	7	7.2	7.1	6.9	7	7	6.2	6.3	6.4	5.2	5.4	5.6		5.2	5.4	5.6	205
210	6.7	7.3	7.3	6.8	7.2	7.2	6.9	7.1	7.1	6.7	6.9	7	6.1	6.2	6.3	5	5.3	5.5		5	5.3	5.5	210
215	6.6	7.3	7.3	6.7	7.2	7.2	6.7	7.1	7.1	6.6	6.9	7	6	6	6.2	4.9	5.1	5.3		4.8	5.1	5.3	215
220	6.4	7.3	7.3	6.5	7.2	7.2	6.6	7	7.1	6.4	6.9	7	5.9	5.9	6.1	4.7	5	5.2		4.6	4.9	5.2	220
225	6.3	7.3	7.3	6.4	7.2	7.2	6.4	6.9	7.1	6.2	6.8	7	5.7	5.8	6	4.5	4.8	5		4.5	4.7	5	225
230	6.2	7.3	7.3	6.3	7.2	7.2	6.3	6.8	7	5.9	6.6	6.9	5.6	5.7	5.9	4.3	4.6	4.9		4.3	4.6	4.8	230
235	6.1	7.3	7.3	6.2	7.2	7.2	6.2	6.7	6.9	5.7	6.4	6.7	5.4	5.6	5.7	4.1	4.5	4.7		4	4.4	4.7	235
240	6	7.3	7.3	6.1	7.2	7.2	6.1	6.6	6.8	5.5	6	6.3	5.1	5.4	5.6	3.9	4.3	4.6		3.8	4.2	4.5	240
245	5.9	7.2	7.2	6	7.1	7.2	6	6.4	6.6	5.3	5.7	5.9	4.7	5.3	5.5	3.6	4.1	4.3		3.6	4	4.3	245
250	5.8	6.7	7	5.9	6.7	6.9	6	6.3	6.5	5.2	5.3	5.5	4.4	5	5.2	3.5	3.8	4.1		3.4	3.8	4	250
255	5.8	6.5	6.6	5.8	6.5	6.7	5.7	6.2	6.3	5	5.1	5.3	4.1	4.6	4.9	3.2	3.6	3.9		3.2	3.6	3.8	255
260	5.3	6.3		5.6	6.1	6.1	5.3	6	6.1	4.9	5	5.2	3.8	4.3	4.5	3	3.4	3.6		2.9	3.4	3.6	260
265	4.2	4.9		5.4	5.6	5.5	5	5.5	5.6	4.7	4.9	5.1	3.5	3.9	4.1	2.8	3.2	3.4		2.6	3.1	3.3	265
270				5.1	5.3	5.3	4.7	5	5.2	4.5	4.8	4.9	3.1	3.6	3.8	2.6	3	3.2		2.4	2.8	3	270
275				4.1	4.8		4.3	4.7	4.8	4.1	4.6	4.7	2.7	3.3	3.4	2.4	2.8	2.9			2.6	2.7	275
280				3.2	4		4.1	4.3	4.3	3.6	4.2	4.3	2.2	2.9	3		2.5	2.7			2.3	2.4	280
285							3.9	4.1	4.1	3.2	3.7	3.8		2.5	2.7		2.2	2.4					285
290							2.6	3.8		2.8	3.3	3.3			2.2								290
295										2.5	2.9	2.8											295
300											2.5	2.3											300

*only possible in TNZK mode - uniquement possible en cas de fonctionnement de la pointe pliante hydraulique de la flèche télescopique (TNZK)

Lifting heights

Hauteurs de levage

TVK/TVNZK

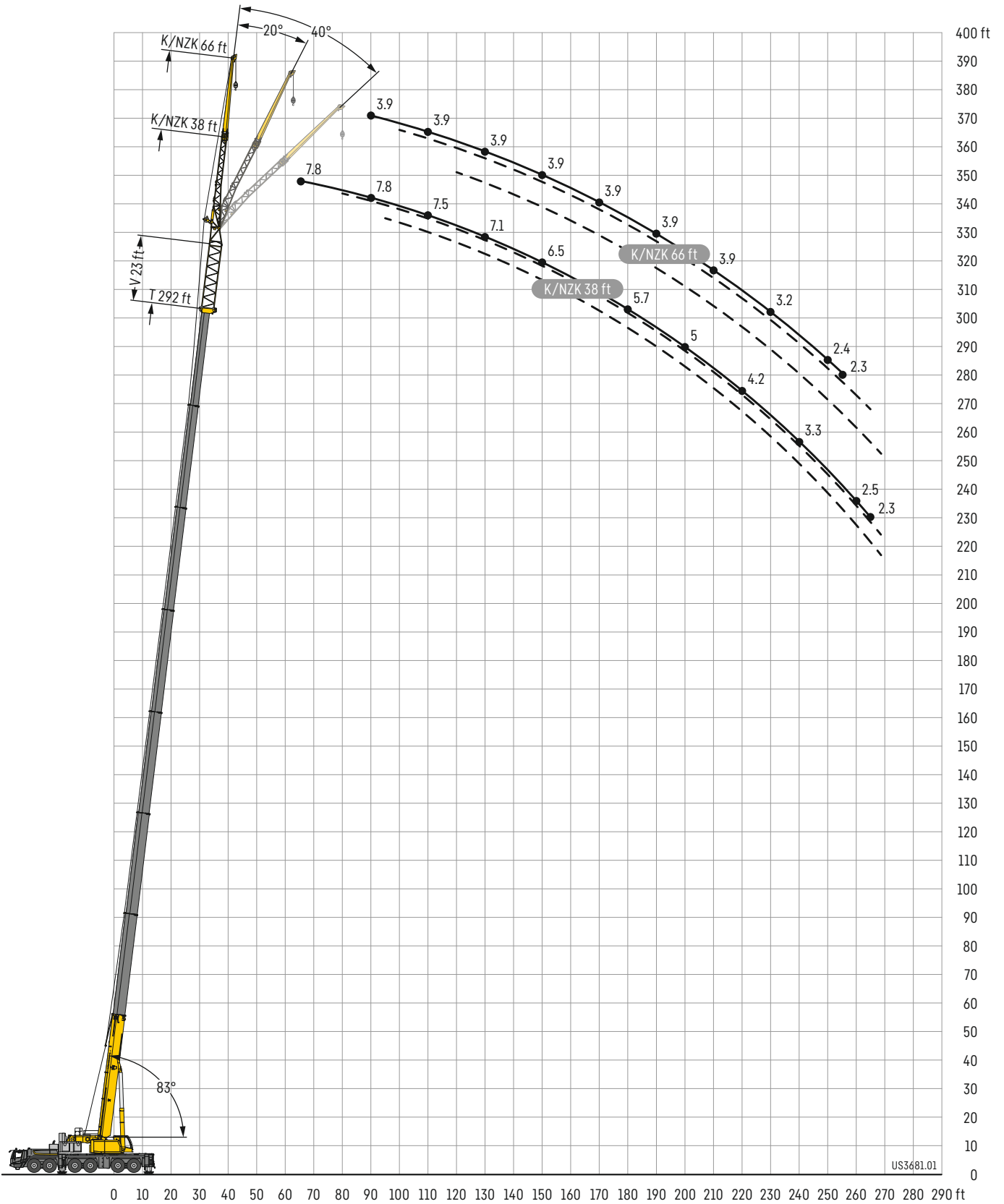

Lifting capacities

Forces de levage

TVK/TVNZK

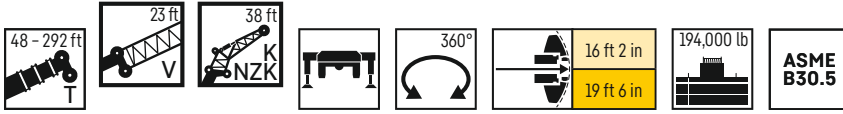

	48 ft + V 23 ft			114 ft + V 23 ft			130 ft + V 23 ft			146 ft + V 23 ft			162 ft + V 23 ft			179 ft + V 23 ft			195 ft + V 23 ft				
	K/NZK 38 ft																						
	0°	20°	40°	0°	20°	40°	0°	20°	40°	0°	20°	40°	0°	20°	40°	0°	20°	40°	0°	20°	40°		
17	53.6																					17	
18	53.6																					18	
19	53.6																					19	
20	53.6																					20	
22	53.2			50.7																		22	
24	51.5	41		50			48.7															24	
26	49.3	40.1		49.1			48			45.6												26	
28	47.2	38.8		48.2			47.2			45.1												28	
30	45.4	37.3		47.4			46.4			44.6				36.9								30	
32	43.5	35.8	24.4	46.4			45.7			43.9				36.5								32	
34	41.8	34.6	23.8	45.4	37.1		44.8			43.1				36.2			33					34	
36	40.2	33.4	23.3	44.4	36.6		43.9	36.3		42.5				35.8			32.7			24.9		36	
38	38.5	32.1	22.8	43.4	35.8		42.9	35.8		41.6				35.4			32.4			29.5		38	
40	36.9	31.1	22.3	42.4	35.1		41.9	35.1		40.8	34.5			34.8			32			29.2		40	
45	33.7	28.6	21.2	39.9	33.1	22.8	40	33.2	23	39.1	32.8			33.6	29.3		31.1			28.5		45	
50	30.5	26.5	20.2	37.3	31.2	22	37.8	31.5	22.2	37.3	31.4	22.4		32.4	28.2		30.1	26.8		27.8		50	
55	27.7	24.6	19.4	35.2	29.7	21.3	35.7	30	21.6	35.5	29.9	21.7	31.2	27.2	21.2	29.2	25.9			27.1	24.5	55	
60	25.2	22.8	18.7	33.1	28.2	20.7	33.8	28.6	21	33.9	28.6	21.2	29.9	26.1	20.7	28.3	25	20.6		26.4	23.9	60	
65	22.9	21	18	31.3	26.9	20.1	32.1	27.3	20.4	32.3	27.5	20.6	28.8	25.2	20.2	27.3	24.2	20.1		25.6	23.1	20	65
70	20.8	19.5	17.5	29.7	25.6	19.6	30.5	26.2	19.9	30.9	26.3	20.1	27.7	24.1	19.7	26.5	23.5	19.7		24.9	22.5	19.6	70
75	19.1	18.2	17.2	28.2	24.4	19.1	29.1	25	19.4	29.5	25.3	19.7	26.7	23.2	19.3	25.6	22.7	19.3		24.2	21.9	19.2	75
80	17.5	17	16.5	26.8	23.4	18.7	27.7	24	19	28.2	24.3	19.3	25.7	22.3	18.9	24.8	21.9	18.9		23.6	21.2	18.9	80
85	16.2	15.9	15.6	25.4	22.3	18.3	26.5	23.1	18.6	26.9	23.4	18.9	24.8	21.5	18.6	24	21.2	18.6		23	20.7	18.6	85
90	15	15	14.9	24.2	21.2	18	25.3	22.2	18.3	25.9	22.6	18.5	23.9	20.8	18.3	23.2	20.5	18.3		22.3	20.1	18.2	90
95	13.9	14.2	14.2	23.1	20.2	17.6	24.2	21.2	18	24.8	21.8	18.2	23.1	20.1	18	22.5	19.9	17.9		21.7	19.6	17.9	95
100	13	13.5		21.9	19.3	17.3	23.2	20.3	17.7	23.8	21	17.9	22.2	19.4	17.6	21.8	19.3	17.6		21.1	19	17.5	100
105				20.8	18.5	17	22.2	19.5	17.4	22.9	20.2	17.7	21.5	18.7	17.2	21.1	18.7	17.1		20.6	18.5	17.1	105
110				19.9	17.8	16.6	21.3	18.8	17	22.1	19.5	17.4	20.6	18.1	16.8	20.5	18.1	16.7		20	17.9	16.7	110
115				18.9	17.1	16.2	20.4	18	16.7	21.3	18.8	17.1	19.9	17.6	16.3	19.9	17.6	16.3		19.4	17.5	16.3	115
120				18.1	16.4	15.7	19.5	17.4	16.4	20.5	18.2	16.8	19.2	17	16	19.2	17.1	16		18.9	17	15.9	120
125				17.2	15.9	15.3	18.6	16.8	16	19.7	17.5	16.4	18.6	16.6	15.6	18.6	16.6	15.6		18.4	16.6	15.5	125
130				16.4	15.3	14.9	17.9	16.2	15.5	19	17	16	17.9	16.1	15.2	18	16.2	15.3		18	16.2	15.2	130
135				15.7	14.8	14.6	17.2	15.7	15.2	18.3	16.5	15.7	17.4	15.7	14.9	17.6	15.8	14.9		17.5	15.8	14.9	135
140				15	14.4	14.3	16.5	15.2	14.8	17.6	16	15.3	16.8	15.3	14.6	17	15.4	14.7		17	15.4	14.7	140
145				14.4	13.9	14	15.9	14.8	14.5	17	15.5	15	16.3	14.9	14.3	16.5	15	14.4		16.5	15	14.4	145
150				13.8	13.6	13.8	15.3	14.4	14.2	16.4	15.1	14.7	15.7	14.5	14.1	16	14.7	14.2		16	14.7	14.1	150
155				13.3	13.3	11.6	14.7	14	14	15.8	14.7	14.4	15.2	14.2	13.8	15.6	14.4	13.9		15.4	14.4	13.9	155
160				12.9	13	7.3	14.1	13.7	13.7	15.3	14.3	14.1	14.8	13.9	13.6	15.1	14	13.7	14.8	14.1	13.7	13.5	160
165				12.5	12.9		13.6	13.4	13.3	14.8	13.9	13.8	14.3	13.6	13.4	14.7	13.8	13.5	14	13.7	13.7	13.5	165
170							13.2	13.1	10.9	14.3	13.6	13.5	13.9	13.3	13.2	14.3	13.5	13.2	13.2	13.2	13.2	13.1	170
175							12.8	12.8	7.3	13.8	13.3	13.1	13.4	13	13	13.9	13.2	13	12.4	12.6	12.7	175	
180							12.2	12.8		13.4	13.1	12.6	13.1	12.7	12.7	13.5	12.9	12.7	11.6	12	12.2	180	
185							8			13	12.9	10.3	12.8	12.4	12.4	13.2	12.7	12.4	11	11.4	11.7	185	
190										13	12.6	7.3	12.5	12.2	12.1	12.8	12.4	12.2	10.3	10.8	11	190	
195										11	11.8		12.2	11.9	11.2	12.4	12.2	11.9	9.8	10.2	10.4	195	
200										8			11.8	11.7	8.9	11.6	11.9	11.7	9.4	9.7	9.8	200	
205													10.4	11.4	6.7	10.8	11.2	11.3	9	9.2	9.3	205	
210													8.4	9	4.8	10.2	10.5	10.5	8.8	8.7	8.8	210	
215													7.3	7.9		9.2	9.8	8.3	8.7	8.6	8.8	215	
220																8.3	8.4	6.4	8.5	8.5	8.7	220	
225																7.9	8.2	4.9	8.4	8.3	8.5	225	
230																6.2	6.3		8.1	8.2	7.9	230	
235																			7.3	7.9	6.4	235	
240																			6.3	6.4	4.9	240	
245																			5.1	5.8		245	

Lifting capacities

Forces de levage

TVK/TVNZK

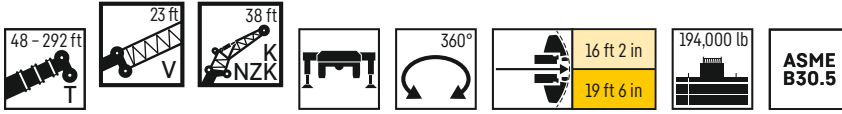

	211 ft + V 23 ft			227 ft + V 23 ft			243 ft + V 23 ft			260 ft + V 23 ft			276 ft + V 23 ft			292 ft + V 23 ft			
	K/NZK 38 ft																		
	0°	20°	40°	0°	20°	40°	0°	20°	40°	0°	20°	40°	0°	20°	40°	0°	20°	40°	
40	22.4																		40
45	22			18.9															45
50	21.7			18.7			15.8												50
55	21.3	20.2		18.5			15.7			12.2									55
60	21	19.8		18.2	17.5		15.6			12.2			10						60
65	20.6	19.4		18	17.2		15.4	15		12.1			10			7.8			65
70	20.2	18.9	17.4	17.7	17		15.2	14.8		12.1	11.9		10			7.8			70
75	19.8	18.3	16.9	17.4	16.7	15.7	15.1	14.6	13.6	11.9	11.7		10	9.7		7.8			75
80	19.1	17.7	16.4	17.1	16.1	15.3	14.9	14.4	13.4	11.7	11.5		9.9	9.6		7.8	7.8		80
85	18.5	17.1	15.9	16.7	15.6	14.9	14.7	14.1	13.3	11.5	11.3	11.1	9.8	9.5	9.4	7.8	7.7		85
90	17.8	16.4	15.4	16.2	15.1	14.6	14.4	13.8	13.1	11.3	11.1	11	9.6	9.5	9.4	7.8	7.7		90
95	17.2	15.9	15	15.7	14.7	14.1	14.1	13.4	12.9	11.1	10.9	10.7	9.5	9.4	9.4	7.7	7.6	7.6	95
100	16.6	15.3	14.6	15.2	14.3	13.7	13.8	13	12.6	10.9	10.7	10.5	9.4	9.4	9.4	7.6	7.6	7.6	100
105	16	14.8	14.2	14.8	13.8	13.3	13.4	12.7	12.4	10.7	10.4	10.3	9.2	9.3	9.3	7.6	7.6	7.6	105
110	15.5	14.3	13.8	14.3	13.4	13	13.1	12.4	12	10.5	10.2	10	9.1	9.1	9.2	7.5	7.5	7.6	110
115	14.9	13.8	13.4	13.9	13	12.6	12.8	12.1	11.8	10.3	9.9	9.8	8.9	8.9	9	7.4	7.5	7.6	115
120	14.4	13.4	13	13.5	12.6	12.2	12.4	11.7	11.5	10.1	9.8	9.6	8.7	8.7	8.8	7.3	7.4	7.5	120
125	14	13	12.6	13	12.3	11.9	12.1	11.5	11.2	9.9	9.5	9.4	8.6	8.5	8.6	7.2	7.3	7.4	125
130	13.5	12.6	12.2	12.7	11.9	11.6	11.7	11.2	11	9.7	9.3	9.2	8.4	8.3	8.4	7.1	7.1	7.2	130
135	13.1	12.3	11.9	12.3	11.6	11.4	11.5	11	10.8	9.4	9.1	9	8.2	8.1	8.2	6.9	7	7.1	135
140	12.7	11.9	11.6	12	11.3	11.1	11.2	10.7	10.6	9.2	9	8.9	8	8	8	6.8	6.8	6.9	140
145	12.2	11.6	11.3	11.7	11.1	10.9	11	10.5	10.4	9.1	8.8	8.7	7.8	7.8	7.9	6.7	6.7	6.8	145
150	11.9	11.2	11.1	11.4	10.8	10.7	10.7	10.3	10.2	8.9	8.6	8.5	7.6	7.6	7.7	6.5	6.5	6.6	150
155	11.6	10.9	10.8	11.1	10.6	10.5	10.5	10.1	10	8.7	8.4	8.4	7.5	7.4	7.5	6.4	6.4	6.5	155
160	11.2	10.7	10.6	10.8	10.4	10.3	10.3	10	9.9	8.5	8.3	8.2	7.3	7.3	7.4	6.3	6.3	6.3	160
165	10.9	10.5	10.4	10.6	10.1	10.1	10.1	9.8	9.7	8.3	8.1	8	7.1	7.1	7.2	6.1	6.1	6.2	165
170	10.6	10.2	10.1	10.3	10	9.9	9.9	9.6	9.6	8.2	7.9	7.9	7	6.9	7.1	6	6	6.1	170
175	10.4	10	10	10.1	9.8	9.7	9.7	9.5	9.4	8	7.8	7.8	6.8	6.8	6.9	5.9	5.8	5.9	175
180	10.2	9.8	9.8	9.9	9.6	9.6	9.4	9.3	9.3	7.9	7.7	7.6	6.6	6.6	6.7	5.7	5.7	5.8	180
185	10	9.6	9.6	9.6	9.5	9.4	9.1	9.1	9.1	7.7	7.5	7.5	6.5	6.5	6.6	5.6	5.6	5.7	185
190	9.7	9.5	9.5	9.3	9.2	9.3	8.8	8.8	8.9	7.5	7.4	7.4	6.4	6.4	6.4	5.4	5.5	5.6	190
195	9.4	9.3	9.3	9	9.1	9.1	8.5	8.6	8.7	7.4	7.2	7.2	6.2	6.2	6.3	5.2	5.3	5.4	195
200	9.1	9.1	9.1	8.8	8.8	8.8	8.1	8.3	8.5	7.2	7.1	7.1	6.1	6.1	6.2	5	5.1	5.3	200
205	9	8.9	8.9	8.6	8.6	8.7	7.7	8	8.2	7.1	7	7	5.9	5.9	6	4.8	5	5.1	205
210	8.8	8.7	8.8	8.3	8.4	8.5	7.3	7.7	7.9	6.9	6.9	6.9	5.8	5.8	5.9	4.6	4.8	4.9	210
215	8.7	8.5	8.7	8.1	8.2	8.3	6.9	7.3	7.5	6.7	6.8	6.8	5.6	5.7	5.7	4.4	4.6	4.8	215
220	8.5	8.4	8.6	7.8	8	8.1	6.8	6.9	7.1	6.3	6.6	6.7	5.5	5.5	5.6	4.2	4.4	4.6	220
225	8.3	8.3	8.5	7.6	7.7	7.8	6.6	6.6	6.7	6	6.3	6.4	5.3	5.4	5.5	4	4.3	4.4	225
230	7.7	8.1	8.2	7.4	7.5	7.6	6.4	6.4	6.5	5.6	5.9	6.1	5.1	5.2	5.3	3.8	4	4.2	230
235	7.1	7.5	7.6	6.9	7.2	7.4	6.3	6.3	6.4	5.2	5.5	5.7	4.8	5.1	5.2	3.6	3.8	4	235
240	6.6	6.9	6.9	6.4	6.8	6.9	6.1	6.2	6.3	5.1	5.1	5.3	4.4	4.8	4.9	3.3	3.6	3.7	240
245	6.3	6.4	6.4	6.3	6.3	6.4	5.9	6.1	6.2	4.9	5	5.1	4.1	4.4	4.6	3.1	3.4	3.5	245
250	6.2	6.2	6	5.8	6.1	6.2	5.6	5.9	5.9	4.8	4.9	5	3.8	4.1	4.2	2.9	3.1	3.3	250
255	5.1	5.7	4.9	5.4	5.6	5.6	5.1	5.5	5.6	4.7	4.7	4.8	3.4	3.8	3.9	2.7	2.9	3	255
260	4	4.5		5.2	5.2	5.3	4.7	5	5.1	4.5	4.6	4.7	3.1	3.4	3.5	2.5	2.7	2.8	260
265				4.8	5	5	4.4	4.6	4.7	4.2	4.4	4.5	2.8	3.1	3.2	2.3	2.5	2.6	265
270				3.8	4.3	4	4	4.3	4.3	3.8	4.1	4.2	2.4	2.7	2.8		2.3	2.4	270
275				2.9	3.6		3.9	4	4	3.3	3.7	3.7		2.4	2.5				275
280							3.6	3.8	3.7	2.9	3.2	3.3							280
285							2.3	3	2.6	2.5	2.8	2.8							285
290											2.4	2.4							290

Lifting capacities

Forces de levage

TVK/TVNZK

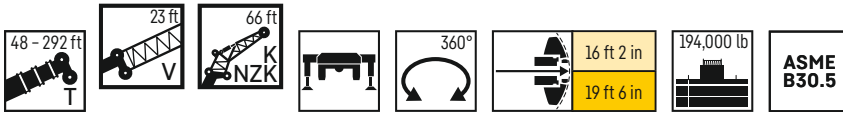

	48 ft + V 23 ft			114 ft + V 23 ft			130 ft + V 23 ft			146 ft + V 23 ft			162 ft + V 23 ft			179 ft + V 23 ft			195 ft + V 23 ft				
	K/NZK 66 ft																						
	0°	20°	40°	0°	20°	40°	0°	20°	40°	0°	20°	40°	0°	20°	40°	0°	20°	40°	0°	20°	40°		
22	19																					22	
24	19.5			17.8																		24	
26	19.5			18.1			17.8															26	
28	19.4			18.2			17.8			17.4												28	
30	19.2			18.2			17.9			17.4												30	
32	19			18.1			17.8			17.3			15.8									32	
34	18.7			18.1			17.8			17.3			15.7									34	
36	18.5	14.1		17.9			17.7			17.2			15.7			14.9						36	
38	18.1	13.8		17.9			17.6			17.2			15.6			14.9						38	
40	17.6	13.5		17.8			17.5			17.1			15.6			14.8			14			40	
45	16.6	12.8		17.4			17.3			16.9			15.4			14.7				13.9		45	
50	15.6	12.1		17	12.8		17	12.9		16.6			15.3			14.5				13.8		50	
55	14.7	11.4	9.4	16.6	12.3		16.6	12.4		16.3	12.4		15.1			14.4				13.7		55	
60	13.9	10.9	9.1	16	11.8		16.1	11.9		16	12		14.8	11.5		14.2	11.3			13.5		60	
65	13	10.5	8.9	15.4	11.4	9.1	15.6	11.5		15.6	11.6		14.5	11.1		14	11			13.3	10.8	65	
70	11.9	10.1	8.6	14.8	11	8.9	15.1	11.1	8.9	15.1	11.2	8.9	14.2	10.8		13.7	10.7			13.1	10.6	70	
75	10.9	9.7	8.4	14.2	10.7	8.8	14.5	10.8	8.8	14.7	10.9	8.8	13.8	10.6	8.7	13.3	10.5			12.9	10.3	75	
80	10.2	9.4	8.3	13.6	10.4	8.6	14	10.5	8.6	14.1	10.6	8.6	13.4	10.4	8.5	13	10.3	8.4		12.6	10.1	8.4	80
85	9.5	9.1	8.1	13	10.2	8.4	13.4	10.3	8.5	13.6	10.4	8.5	13	10.1	8.4	12.6	10	8.3		12.2	9.9	8.3	85
90	8.9	8.8	8	12.5	9.9	8.3	12.9	10	8.4	13.2	10.2	8.4	12.5	9.9	8.3	12.3	9.9	8.2		12	9.7	8.2	90
95	8.4	8.6	7.9	12	9.6	8.2	12.4	9.8	8.2	12.7	9.9	8.3	12.2	9.7	8.2	12	9.7	8.1		11.7	9.6	8.1	95
100	7.9	8.3	7.8	11.5	9.4	8.1	12	9.6	8.1	12.3	9.7	8.2	11.8	9.5	8.1	11.6	9.5	8		11.4	9.4	8	100
105	7.5	8.2	7.8	11	9.2	8	11.5	9.4	8	11.9	9.5	8.1	11.4	9.3	8	11.3	9.3	7.9		11.1	9.2	7.9	105
110	7.1	8	7.8	10.5	9	7.9	11.1	9.2	7.9	11.5	9.3	8	11.1	9.2	7.9	11.1	9.1	7.9		10.9	9.1	7.8	110
115	6.7	7.9	7.8	10	8.8	7.8	10.6	9	7.9	11.1	9.1	7.9	10.8	9	7.8	10.8	9	7.8		10.6	8.9	7.8	115
120	6.4	7.8	7.8	9.6	8.7	7.8	10.2	8.8	7.8	10.7	8.9	7.8	10.6	8.8	7.7	10.5	8.8	7.7		10.4	8.8	7.7	120
125	6.2	7.7		9.2	8.5	7.7	9.8	8.7	7.7	10.3	8.8	7.7	10.3	8.7	7.7	10.3	8.7	7.7		10.2	8.6	7.6	125
130	5.9			8.8	8.4	7.7	9.4	8.5	7.7	10	8.6	7.7	10	8.6	7.6	10.1	8.5	7.6		10	8.5	7.6	130
135				8.4	8.2	7.6	9.1	8.4	7.6	9.6	8.5	7.6	9.7	8.4	7.6	9.8	8.4	7.5		9.8	8.4	7.5	135
140				8.1	8.1	7.6	8.7	8.3	7.6	9.3	8.4	7.6	9.4	8.3	7.6	9.6	8.3	7.5		9.6	8.3	7.5	140
145				7.8	8	7.6	8.4	8.1	7.6	8.9	8.2	7.6	9.1	8.2	7.5	9.3	8.2	7.5		9.4	8.2	7.4	145
150				7.5	7.9	7.6	8.1	8	7.6	8.6	8.1	7.5	8.8	8.1	7.5	9.1	8.1	7.4		9.2	8.1	7.4	150
155				7.3	7.8	7.6	7.8	7.9	7.6	8.3	8	7.5	8.5	8	7.5	8.8	8	7.4		9	8	7.4	155
160				7	7.7	7.6	7.6	7.8	7.6	8.1	7.9	7.5	8.2	7.9	7.5	8.5	7.9	7.4		8.7	7.9	7.4	160
165				6.8	7.7	7.6	7.4	7.7	7.6	7.8	7.8	7.5	8	7.8	7.5	8.3	7.8	7.4		8.5	7.8	7.3	165
170				6.6	7.6	7.6	7.1	7.7	7.6	7.6	7.8	7.5	7.8	7.7	7.5	8.1	7.8	7.4		8.3	7.7	7.3	170
175				6.4	7.6	7.6	6.9	7.6	7.6	7.4	7.7	7.5	7.6	7.7	7.5	7.8	7.7	7.4		8.1	7.7	7.3	175
180				6.2	7.6	7.6	6.7	7.6	7.6	7.1	7.6	7.5	7.3	7.6	7.5	7.6	7.6	7.4		7.9	7.6	7.3	180
185				6.1	7.6	7.6	6.5	7.6	7.6	7	7.6	7.5	7.2	7.5	7.5	7.4	7.6	7.4		7.7	7.6	7.3	185
190				5.9	7.6		6.4	7.6	7.6	6.8	7.5	7.5	7	7.5	7.5	7.3	7.5	7.4		7.5	7.5	7.3	190
195				5.8			6.2	7.6	7.6	6.6	7.5	7.5	6.8	7.5	7.5	7.1	7.5	7.4		7.3	7.5	7.3	195
200							6	7.6	7.6	6.4	7.5	7.5	6.7	7.5	7.5	6.9	7.4	7.4		7.2	7.4	7.3	200
205							5.9	7.6		6.3	7.5	7.5	6.5	7.5	7.5	6.8	7.4	7.4		7	7.4	7.3	205
210							5.8			6.1	7.5	7.5	6.4	7.5	7.5	6.6	7.4	7.4		6.8	7.3	7.3	210
215										6	7.5	7.5	6.3	7.5	7.5	6.5	7.4	7.4		6.7	7.3	7.3	215
220										5.9	7.5		6.1	7.5	7.5	6.4	7.4	7.4		6.6	7.3	7.3	220
225										5.8	7.5		6	7.5	7.5	6.2	7.4	7.4		6.5	7.3	7.3	225
230													5.9	7.5	7.5	6.1	7.4	7.4		6.3	7.2	7.3	230
235													5.9	7.5		6	7.4	7.4		6.2	7	7.2	235
240													5.7	6		6	7.4	7.4		6	6.6	6.8	240
245													3.8			5.9	7.3	7.1		5.9	6	6.1	245
250																5.7	6.1			5.8	5.8	6.1	250
255																5	5.8			5.7	5.7	6.1	255
260																3.5				5.6	5.7	6.1	260
265																				4.9	5.6		265
270																				4.3	4.8		270
275																				3.2			275

Lifting capacities

Forces de levage

TVK/TVNZK

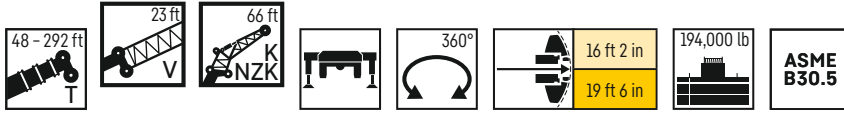

	211 ft + V 23 ft			227 ft + V 23 ft			243 ft + V 23 ft			260 ft + V 23 ft			276 ft + V 23 ft			292 ft + V 23 ft			
	K/NZK 66 ft																		
	0°	20°	40°	0°	20°	40°	0°	20°	40°	0°	20°	40°	0°	20°	40°	0°	20°*	40°*	
45	12.2																		45
50	12			10.8															50
55	11.9			10.7			9.7												55
60	11.8			10.6			9.6			8									60
65	11.6			10.6			9.5			8									65
70	11.5	10		10.5			9.5			8									70
75	11.3	9.8		10.4	9.4		9.4			8			6.1						75
80	11.2	9.6		10.3	9.2		9.3	8.7		7.9			6.1						80
85	11	9.4		10.2	9.1		9.3	8.6		7.7	7.3		6.1						85
90	10.9	9.3	7.9	10.1	9		9.2	8.5		7.6	7.3		6.1			3.9			90
95	10.7	9.1	7.9	10	8.8	7.7	9.1	8.4		7.5	7.3		6.1	6.1		3.9			95
100	10.5	9	7.8	9.9	8.7	7.6	9.1	8.3	7.4	7.4	7.2		6.1	6.1		3.9	4.9		100
105	10.3	8.8	7.7	9.7	8.6	7.6	9	8.2	7.3	7.4	7.2	6.9	6.1	6.1		3.9	4.9		105
110	10.2	8.7	7.7	9.6	8.4	7.5	8.9	8.1	7.3	7.3	7.2	6.9	6.1	6.1		3.9	4.9		110
115	10	8.6	7.6	9.5	8.3	7.4	8.8	8	7.2	7.3	7.2	6.9	6.1	6.1	5.8	3.9	4.9		115
120	9.8	8.5	7.6	9.3	8.2	7.4	8.7	7.9	7.2	7.2	7.1	6.9	6	6	5.8	3.9	4.9	4.8	120
125	9.6	8.4	7.5	9.2	8.1	7.4	8.6	7.8	7.2	7.2	7.1	6.9	6	6	5.8	3.9	4.9	4.8	125
130	9.5	8.3	7.4	9.1	8	7.3	8.5	7.7	7.1	7.1	7.1	6.9	6	6	5.8	3.9	4.9	4.8	130
135	9.3	8.2	7.4	8.9	8	7.3	8.5	7.7	7.1	7.1	7.1	6.9	5.9	6	5.8	3.9	4.9	4.8	135
140	9.2	8.1	7.4	8.8	7.9	7.2	8.4	7.6	7.1	7	7	6.9	5.9	6	5.8	3.9	4.9	4.8	140
145	9	8	7.3	8.7	7.8	7.2	8.2	7.5	7	6.9	6.9	6.8	5.9	6	5.8	3.9	4.9	4.8	145
150	8.8	7.9	7.3	8.6	7.7	7.2	8.1	7.5	7	6.9	6.7	6.7	5.8	6	5.8	3.9	4.9	4.8	150
155	8.6	7.8	7.3	8.4	7.6	7.2	8	7.4	7	6.8	6.6	6.5	5.8	6	5.8	3.9	4.9	4.8	155
160	8.5	7.7	7.2	8.3	7.6	7.1	7.9	7.3	7	6.7	6.5	6.4	5.8	5.9	5.8	3.9	4.8	4.8	160
165	8.3	7.6	7.2	8.1	7.5	7.1	7.7	7.3	7	6.6	6.3	6.3	5.7	5.8	5.8	3.9	4.8	4.8	165
170	8.1	7.6	7.2	7.9	7.4	7.1	7.6	7.2	7	6.4	6.2	6.2	5.7	5.7	5.8	3.9	4.8	4.8	170
175	8	7.5	7.2	7.8	7.3	7.1	7.5	7.1	6.9	6.3	6.1	6.1	5.6	5.6	5.7	3.9	4.7	4.8	175
180	7.8	7.4	7.2	7.6	7.2	7.1	7.3	7	6.9	6.2	6	6	5.4	5.5	5.6	3.9	4.7	4.8	180
185	7.6	7.3	7.2	7.4	7.1	7	7.2	6.9	6.8	6.1	5.8	5.9	5.3	5.4	5.5	3.9	4.6	4.7	185
190	7.4	7.2	7.1	7.3	7	6.9	7	6.8	6.8	5.9	5.7	5.7	5.2	5.3	5.4	3.9	4.5	4.6	190
195	7.3	7	7	7.1	6.9	6.8	6.9	6.7	6.7	5.8	5.6	5.6	5.1	5.1	5.2	3.9	4.4	4.5	195
200	7.1	6.9	6.9	7	6.7	6.8	6.8	6.6	6.6	5.7	5.5	5.5	4.9	5	5.1	3.9	4.3	4.4	200
205	7	6.8	6.8	6.8	6.6	6.7	6.7	6.5	6.5	5.6	5.4	5.4	4.8	4.9	5	3.9	4.2	4.3	205
210	6.8	6.7	6.7	6.7	6.5	6.6	6.6	6.4	6.4	5.5	5.3	5.4	4.7	4.8	4.9	3.9	4.1	4.2	210
215	6.7	6.5	6.6	6.6	6.4	6.5	6.4	6.3	6.3	5.4	5.2	5.3	4.6	4.7	4.8	3.7	4	4.1	215
220	6.6	6.4	6.5	6.5	6.3	6.4	6.3	6.2	6.3	5.3	5.1	5.2	4.5	4.6	4.7	3.5	3.9	4	220
225	6.4	6.3	6.4	6.3	6.2	6.3	6.1	6.1	6.2	5.2	5.1	5.1	4.4	4.5	4.6	3.4	3.7	3.9	225
230	6.3	6.2	6.3	6.2	6.1	6.2	5.7	6	6.1	5.1	5	5	4.2	4.4	4.5	3.2	3.6	3.8	230
235	6.2	6.1	6.3	6.1	6	6.2	5.4	5.8	6	5	4.9	5	4.1	4.2	4.4	3	3.4	3.6	235
240	6	6	6.2	6	5.9	6.1	5	5.5	5.9	4.8	4.8	4.9	3.9	4.1	4.3	2.8	3.2	3.5	240
245	5.9	5.9	6.1	5.9	5.8	6	4.8	5.2	5.5	4.4	4.7	4.8	3.8	4	4.2	2.6	3	3.3	245
250	5.8	5.8	6	5.8	5.7	5.9	4.7	4.9	5.2	4.1	4.6	4.7	3.6	3.9	4	2.4	2.8	3.1	250
255	5.7	5.7	6	5.5	5.6	5.9	4.6	4.6	4.8	3.8	4.3	4.5	3.4	3.7	3.9	2.3	2.6	2.9	255
260	5.4	5.7	5.9	5.1	5.5	5.8	4.6	4.5	4.7	3.7	4	4.2	3.2	3.6	3.8		2.5	2.7	260
265	5.1	5.4	5.4	4.6	5.2	5.5	4.5	4.5	4.6	3.6	3.7	3.9	2.9	3.4	3.6		2.3	2.5	265
270	4.9	5.1	5.1	4.4	4.8	4.9	4.4	4.4	4.6	3.5	3.6	3.7	2.6	3.1	3.4			2.3	270
275	4.5	4.8	4.8	4.2	4.4	4.6	4	4.3	4.5	3.3	3.5	3.6	2.3	2.8	3				275
280	4.2	4.4		4	4.2	4.3	3.5	4.1	4.3	3.2	3.4	3.5		2.5	2.7				280
285	3.2	3.8		3.9	4	4	3.3	3.7	3.8	3	3.3	3.4			2.4				285
290				3.5	3.8	3.7	3	3.3	3.5	2.7	3.1	3.2							290
295				2.7	3.4		2.7	3.1	3.1	2.3	2.9	3.1							295
300					2.4		2.5	2.7	2.7		2.5	2.6							300
305							2.2	2.5	2.4										305

*only possible in TVNZK mode · uniquement possible en cas de fonctionnement de la pointe pliante hydraulique de la flèche télescopique (TVNZK)

Lifting heights

Hauteurs de levage

TVK/TVNZK

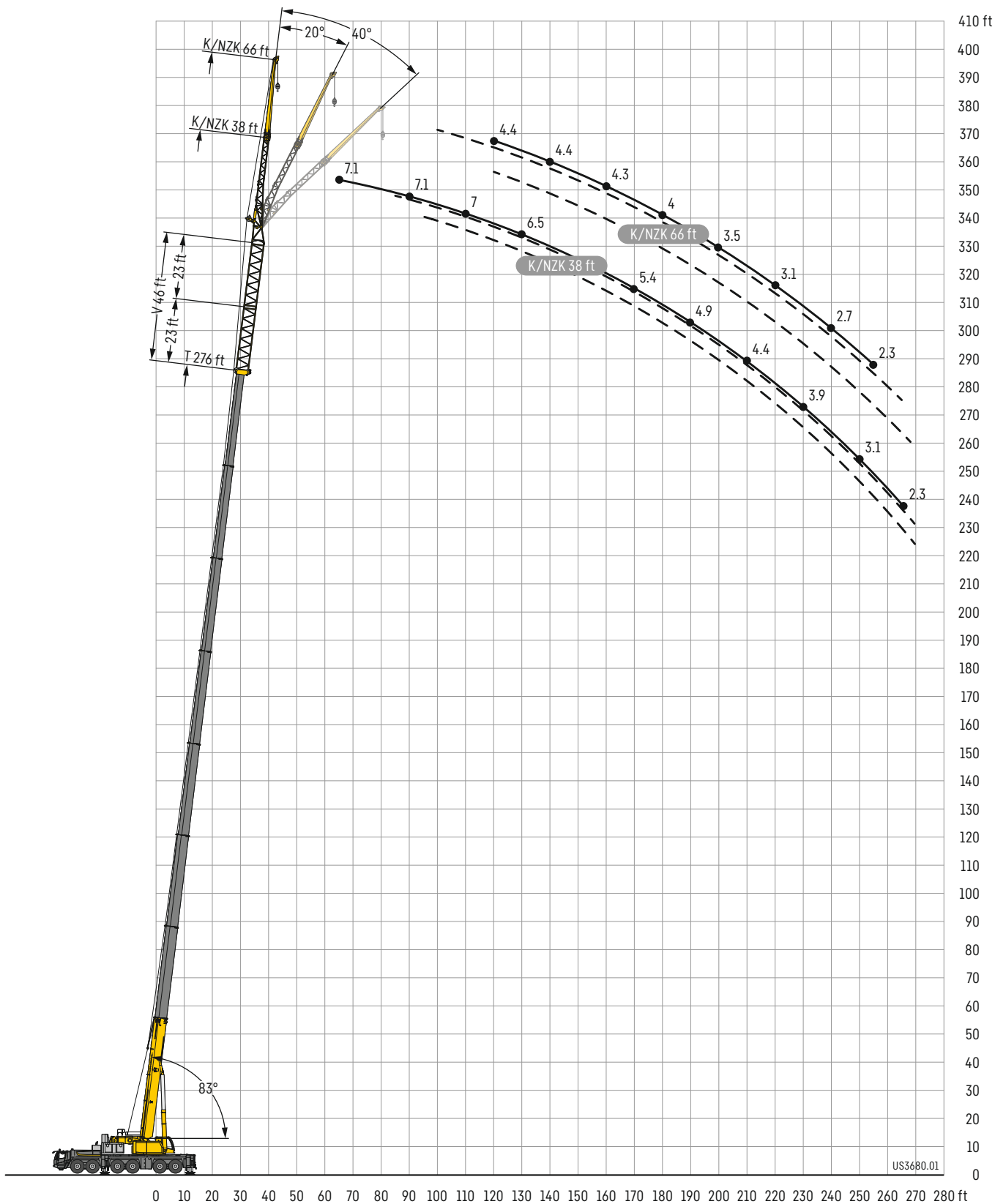

Lifting capacities

Forces de levage

TVK/TVNZK

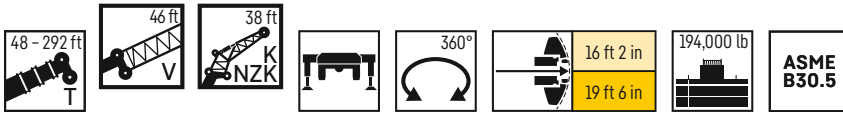

	48 ft + V 46 ft			114 ft + V 46 ft			130 ft + V 46 ft			146 ft + V 46 ft			162 ft + V 46 ft			179 ft + V 46 ft			195 ft + V 46 ft					
	K/NZK 38 ft																							
	0°	20°	40°	0°	20°	40°	0°	20°	40°	0°	20°	40°	0°	20°	40°	0°	20°	40°	0°	20°	40°			
22	41.1																					22		
24	39.6			36.6																		24		
26	38.1	34.2		36																		26		
28	36.7	33		35.3			34.4															28		
30	35.3	31.8		34.5			33.8			32.3												30		
32	33.9	30.7		33.8			33			31.7			24.7									32		
34	32.6	29.5		33			32.4			31.2			24.4									34		
36	31.4	28.5	23.8	32.3			31.7			30.6			24.1			22.1						36		
38	30.2	27.5	23.3	31.5	27.9		31.1			30			23.8			21.8						38		
40	29	26.4	22.9	30.8	27.2		30.4	27		29.5			23.5			21.6				19.7		40		
45	26.2	24.2	21.9	29	25.5		28.8	25.5		28.1	25		22.7			21				19.2		45		
50	23.9	22.2	20.8	27.3	24.1	21.7	27.4	24.1	21.6	26.8	23.8		21.9	20.2		20.3	18.9			18.7		50		
55	21.9	20.3	19.1	25.6	22.8	20.6	25.9	22.8	20.6	25.6	22.7	20.4	21.1	19.4		19.6	18.3			18.2	17.1	55		
60	20	18.5	17.6	24.2	21.4	19.6	24.5	21.7	19.7	24.3	21.6	19.5	20.3	18.7	17.3	19	17.7	16.5		17.7	16.6	60		
65	18.3	17	16.2	22.8	20.3	18.7	23.1	20.6	18.8	23.1	20.5	18.7	19.5	18	16.7	18.4	17	16		17.2	16.1	15.2	65	
70	16.6	15.6	15	21.5	19.3	17.8	21.9	19.5	18	22	19.6	18	18.8	17.3	16.2	17.8	16.5	15.5		16.7	15.6	14.8	70	
75	15.2	14.4	13.9	20.3	18.3	16.9	20.8	18.7	17.1	21	18.7	17.2	18.1	16.6	15.6	17.2	15.9	15		16.2	15.2	14.3	75	
80	14	13.3	12.9	19.2	17.3	16.1	19.8	17.8	16.4	19.9	17.9	16.5	17.4	16	15	16.6	15.4	14.5		15.7	14.7	13.9	80	
85	12.9	12.3	12	18.2	16.5	15.3	18.8	16.9	15.7	19.1	17.2	15.8	16.8	15.5	14.4	16.1	14.9	14.1		15.3	14.2	13.5	85	
90	11.9	11.5	11.3	17.3	15.6	14.5	17.9	16.1	15	18.2	16.4	15.2	16.1	14.9	13.9	15.5	14.4	13.6		14.8	13.8	13.1	90	
95	11.1	10.8	10.6	16.3	14.9	13.9	17	15.4	14.3	17.4	15.7	14.6	15.5	14.4	13.4	15	13.9	13.1		14.4	13.4	12.8	95	
100	10.4	10.2	10.1	15.5	14.1	13.2	16.2	14.8	13.7	16.6	15.1	14.1	15	13.8	12.9	14.5	13.5	12.7		13.9	13	12.4	100	
105	9.8	9.7	9.6	14.7	13.4	12.6	15.4	14.1	13.1	15.9	14.4	13.5	14.5	13.3	12.5	14	13.1	12.3		13.5	12.6	12.1	105	
110	9.3	9.2	9.2	13.9	12.7	12.1	14.7	13.4	12.6	15.2	13.8	13	13.9	12.8	12	13.6	12.6	11.9		13.1	12.3	11.7	110	
115	8.9	8.8	8.8	13.2	12.1	11.6	14	12.8	12.1	14.5	13.3	12.5	13.4	12.4	11.7	13.2	12.2	11.6		12.7	11.9	11.4	115	
120	8.4	8.4	8.2	12.5	11.5	11.2	13.3	12.2	11.6	13.8	12.7	12	13	11.9	11.3	12.7	11.8	11.2		12.4	11.6	11.1	120	
125	8.1	8.1		11.9	11.1	10.7	12.7	11.7	11.2	13.2	12.2	11.6	12.5	11.6	11	12.3	11.5	10.9		12	11.3	10.8	125	
130				11.3	10.7	10.4	12.1	11.2	10.9	12.6	11.7	11.2	12.1	11.2	10.7	11.9	11.1	10.7		11.7	11	10.6	130	
135				10.9	10.3	10.1	11.5	10.8	10.5	12.1	11.3	10.9	11.6	10.8	10.5	11.6	10.8	10.4		11.4	10.7	10.3	135	
140				10.4	10	9.8	11	10.5	10.2	11.6	10.9	10.6	11.2	10.5	10.2	11.2	10.5	10.2		11.1	10.5	10.1	140	
145				10.1	9.6	9.5	10.7	10.2	9.9	11.2	10.5	10.3	10.9	10.3	10	10.9	10.3	10		10.8	10.2	9.9	145	
150				9.7	9.4	9.3	10.3	9.9	9.7	10.7	10.2	10	10.5	10	9.7	10.6	10	9.7		10.5	10	9.7	150	
155				9.4	9.1	9	9.9	9.6	9.4	10.4	9.9	9.8	10.3	9.8	9.5	10.4	9.8	9.6		10.3	9.8	9.5	155	
160				9.1	8.8	8.8	9.6	9.3	9.2	10.1	9.7	9.5	10	9.5	9.3	10.1	9.6	9.4		10	9.6	9.4	160	
165				8.8	8.6	8.6	9.3	9.1	9	9.8	9.4	9.3	9.7	9.3	9.1	9.8	9.4	9.2		9.8	9.4	9.2	165	
170				8.5	8.4	8.5	9	8.8	8.8	9.5	9.1	9.1	9.5	9.1	9	9.6	9.2	9		9.6	9.2	9	170	
175				8.2	8.2	8.3	8.8	8.6	8.6	9.2	8.9	8.9	9.2	8.9	8.8	9.4	9	8.8		9.4	9	8.9	175	
180				8	8	8.1	8.5	8.4	8.5	8.9	8.7	8.7	9	8.7	8.6	9.2	8.8	8.7		9.2	8.8	8.7	180	
185				7.8	7.8	5.6	8.3	8.2	8.3	8.7	8.5	8.5	8.8	8.5	8.5	9	8.6	8.5		9	8.7	8.5	185	
190				7.7	7.8		8.1	8	8.2	8.5	8.3	8.4	8.6	8.3	8.4	8.8	8.4	8.4		8.8	8.5	8.4	190	
195							7.9	7.8	7.9	8.3	8.1	8.2	8.4	8.2	8.3	8.5	8.3	8.3		8.6	8.3	8.3	195	
200							7.7	7.7	5.8	8.1	8	8.1	8.3	8.1	8.1	8.4	8.2	8.2		8.4	8.2	8.2	200	
205							7.5	7.7		7.9	7.8	8	8.1	7.9	8	8.2	8	8		8.2	8	8.1	205	
210										7.7	7.7	7.7	7.9	7.8	7.9	8	7.9	8		8	7.9	8	210	
215										7.4	7.6	5.9	7.7	7.7	7.8	7.9	7.8	7.9		7.7	7.8	7.9	215	
220										6.8	7.4		7.6	7.6	7.8	7.7	7.6	7.8		7.4	7.5	7.7	220	
225													7.5	7.5	7.3	7.6	7.5	7.7		6.9	7.2	7.3	225	
230													7	7.4	5.6	7.5	7.4	7.7		6.3	6.7	6.9	230	
235													5.5	5.5		7.3	7.4	7.6		5.8	6.1	6.2	235	
240													3.7			6.2	6.9	6.8		5.7	5.7	5.8	240	
245																5.4	5.5	5.4		5.6	5.6	5.7	245	
250																4.8	5.3			5.5	5.5	5.6	250	
255																				5.3	5.4	5.6	255	
260																				4.6	5.1	4.7	260	
265																					4.1	4.3		265
270																					2.9	2.9		270

Lifting capacities

Forces de levage

TVK/TVNZK

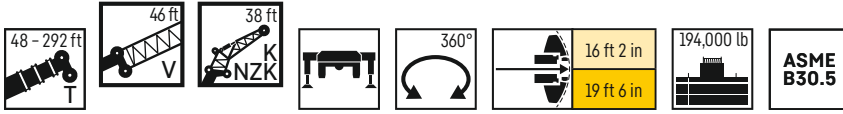

	211 ft + V 46 ft			227 ft + V 46 ft			243 ft + V 46 ft			260 ft + V 46 ft			276 ft + V 46 ft			292 ft + V 46 ft			
	0°	20°	40°	0°	20°	40°	0°	20°	40°	0°	20°	40°	0°	20°	40°	0°	20°*	40°*	
45	15.5																		45
50	15.2			13															50
55	14.9			12.8			10.9												55
60	14.5	13.9		12.5			10.8			8.9									60
65	14.2	13.6		12.3	11.9		10.7			8.9			7.1						65
70	13.9	13.2	12.7	12.1	11.7		10.5	10.4		8.9			7.1						70
75	13.5	12.9	12.4	11.8	11.4	11.2	10.4	10.2		8.8	8.7		7.1						75
80	13.2	12.6	12.1	11.6	11.2	11	10.3	10.1	10	8.7	8.6		7.1						80
85	12.9	12.2	11.7	11.4	11	10.8	10.1	9.9	9.8	8.6	8.5		7.1	7.3					85
90	12.5	11.9	11.3	11.1	10.8	10.6	10	9.8	9.7	8.5	8.5	8.5	7.1	7.2					90
95	12.2	11.5	11	10.9	10.6	10.4	9.9	9.6	9.6	8.4	8.4	8.4	7.1	7.1	7		5.6		95
100	11.9	11.1	10.7	10.8	10.4	10.1	9.7	9.5	9.4	8.3	8.2	8.2	7.1	7.1	7		5.6	5.6	100
105	11.6	10.9	10.4	10.6	10.2	9.9	9.6	9.3	9.3	8.2	8.1	8	7.1	7	7	5.3	5.6	5.6	105
110	11.2	10.6	10.1	10.4	10	9.7	9.4	9.2	9.1	8	7.9	7.9	7	7	6.9	5.3	5.6	5.6	110
115	10.8	10.3	9.9	10.1	9.7	9.4	9.3	9.1	8.9	7.9	7.7	7.7	6.9	6.9	6.9	5.3	5.5	5.6	115
120	10.5	10	9.7	9.9	9.5	9.2	9.2	8.9	8.8	7.7	7.5	7.5	6.8	6.8	6.8	5.3	5.5	5.6	120
125	10.2	9.7	9.4	9.6	9.3	9.1	9	8.7	8.6	7.5	7.4	7.3	6.7	6.7	6.7	5.3	5.5	5.6	125
130	9.9	9.5	9.2	9.4	9	8.8	8.8	8.5	8.4	7.4	7.2	7.2	6.5	6.6	6.6	5.3	5.4	5.6	130
135	9.6	9.2	9	9.1	8.8	8.7	8.6	8.3	8.2	7.2	7	7	6.4	6.4	6.4	5.3	5.3	5.5	135
140	9.4	9	8.8	8.9	8.6	8.5	8.4	8.2	8.1	7.1	6.9	6.9	6.3	6.3	6.3	5.2	5.2	5.4	140
145	9.1	8.8	8.6	8.7	8.4	8.3	8.2	8	7.9	6.9	6.7	6.7	6.1	6.1	6.2	5.1	5.1	5.2	145
150	8.9	8.5	8.4	8.5	8.2	8.1	8	7.8	7.7	6.7	6.6	6.6	6	6	6.1	5	5	5.1	150
155	8.6	8.3	8.2	8.3	8	8	7.8	7.7	7.6	6.6	6.4	6.4	5.8	5.8	5.9	4.8	4.9	5	155
160	8.4	8.1	8.1	8.1	7.8	7.8	7.7	7.5	7.4	6.4	6.3	6.3	5.7	5.7	5.8	4.7	4.8	4.9	160
165	8.2	7.9	7.9	7.9	7.6	7.6	7.5	7.3	7.3	6.3	6.2	6.2	5.5	5.6	5.6	4.6	4.6	4.8	165
170	8	7.7	7.7	7.7	7.5	7.4	7.3	7.2	7.1	6.1	6	6	5.4	5.4	5.5	4.4	4.5	4.6	170
175	7.8	7.5	7.5	7.5	7.3	7.3	7.2	7	7	6	5.9	5.9	5.2	5.3	5.4	4.3	4.4	4.5	175
180	7.6	7.4	7.3	7.3	7.1	7.1	7	6.9	6.9	5.9	5.7	5.8	5.1	5.2	5.2	4.2	4.3	4.4	180
185	7.4	7.2	7.2	7.2	7	7	6.9	6.8	6.7	5.7	5.6	5.6	5	5.1	5.1	4.1	4.1	4.3	185
190	7.2	7	7	7	6.8	6.8	6.8	6.6	6.6	5.6	5.5	5.5	4.9	4.9	5	3.9	4	4.1	190
195	7	6.9	6.9	6.9	6.7	6.7	6.6	6.5	6.5	5.5	5.4	5.4	4.8	4.8	4.9	3.8	3.9	4	195
200	6.8	6.7	6.7	6.7	6.6	6.6	6.5	6.4	6.4	5.4	5.3	5.3	4.6	4.7	4.8	3.7	3.8	3.9	200
205	6.7	6.6	6.6	6.6	6.5	6.5	6.4	6.3	6.3	5.2	5.2	5.2	4.5	4.5	4.6	3.6	3.7	3.8	205
210	6.6	6.4	6.5	6.4	6.3	6.3	6.3	6.1	6.2	5.1	5.1	5.1	4.4	4.4	4.5	3.4	3.5	3.7	210
215	6.4	6.3	6.3	6.3	6.2	6.2	6.1	6	6.1	5	5	5	4.3	4.3	4.4	3.2	3.4	3.5	215
220	6.3	6.2	6.2	6.1	6.1	6.1	5.9	5.9	6	4.9	4.9	4.9	4.2	4.2	4.3	3.1	3.3	3.4	220
225	6.1	6	6.1	6	6	6	5.5	5.7	5.9	4.8	4.8	4.8	4	4.1	4.2	2.9	3.1	3.2	225
230	6	5.9	6	5.8	5.8	5.9	5.1	5.4	5.6	4.7	4.7	4.7	3.9	4	4	2.7	2.9	3	230
235	5.8	5.8	5.9	5.7	5.7	5.7	4.7	5.1	5.2	4.5	4.6	4.6	3.7	3.8	3.9	2.5	2.7	2.9	235
240	5.7	5.7	5.8	5.6	5.6	5.7	4.6	4.7	4.9	4.2	4.4	4.5	3.5	3.7	3.7	2.3	2.5	2.7	240
245	5.6	5.5	5.6	5.5	5.5	5.6	4.5	4.4	4.5	3.9	4.1	4.3	3.4	3.5	3.6		2.4	2.5	245
250	5.5	5.5	5.6	5.2	5.4	5.5	4.4	4.4	4.4	3.6	3.8	4	3.1	3.3	3.4			2.3	250
255	5.1	5.3	5.5	4.8	5.1	5.3	4.3	4.3	4.3	3.5	3.5	3.7	2.8	3.1	3.3				255
260	4.9	5	5	4.3	4.7	4.9	4.2	4.2	4.3	3.3	3.4	3.5	2.6	2.8	3				260
265	4.7	4.8	4.8	4.2	4.2	4.3	4.1	4.1	4.2	3.2	3.3	3.3	2.3	2.6	2.7				265
270	4.2	4.6	4.5	3.9	4.1	4.1	3.7	4	4	3	3.1	3.2		2.2	2.4				270
275	3.9	4	4	3.8	3.8	3.9	3.2	3.6	3.7	2.9	3	3.1							275
280	2.9	3.5	2.9	3.6	3.7	3.7	3	3.1	3.2	2.8	2.8	2.9							280
285				3.2	3.4	3.4	2.7	2.9	3	2.4	2.7	2.7							285
290				2.3	2.8	2.6	2.3	2.6	2.6		2.4	2.4							290
295								2.2	2.2										295

*only possible in TVNZK mode - uniquement possible en cas de fonctionnement de la pointe pliante hydraulique de la flèche télescopique (TVNZK)

Lifting capacities

Forces de levage

TVK/TVNZK

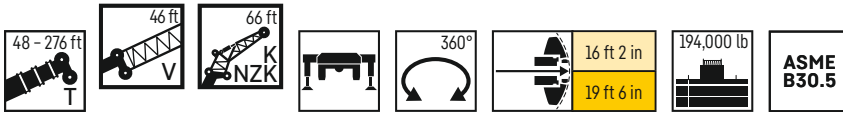

	48 ft + V 46 ft			114 ft + V 46 ft			130 ft + V 46 ft			146 ft + V 46 ft			162 ft + V 46 ft			179 ft + V 46 ft			195 ft + V 46 ft				
	K/NZK 66 ft																						
	0°	20°	40°	0°	20°	40°	0°	20°	40°	0°	20°	40°	0°	20°	40°	0°	20°	40°	0°	20°	40°		
26	17.8																					26	
28	17.8			16.1																		28	
30	17.7			16.2			15.9															30	
32	17.6			16.2			15.8			15.3												32	
34	17.5			16.1			15.8			15.3												34	
36	17.4			16.1			15.7			15.2			13.5									36	
38	17.2			16			15.7			15.2			13.5									38	
40	17	13.6		15.9			15.6			15.1			13.5			12.6						40	
45	16.4	13		15.7			15.4			15			13.4			12.6				11.8		45	
50	15.8	12.4		15.5			15.2			14.8			13.2			12.4				11.6		50	
55	15.1	11.7		15.2	12.1		15	12.1		14.6			13			12.2				11.4		55	
60	14.4	11.2	9.2	14.9	11.7		14.8	11.7		14.4	11.6		12.7			11.9				11.2		60	
65	13.7	10.8	8.9	14.5	11.3		14.4	11.3		14.1	11.3		12.4	10.7		11.7	10.5			11		65	
70	12.9	10.5	8.8	14	11	8.9	13.9	11	8.9	13.7	11		12.1	10.5		11.4	10.3			10.8	10	70	
75	12.1	10.1	8.6	13.4	10.7	8.7	13.4	10.7	8.7	13.3	10.7	8.7	11.7	10.3		11.1	10.1			10.6	9.8	75	
80	11.5	9.8	8.4	12.9	10.4	8.6	13	10.5	8.6	12.8	10.5	8.5	11.4	10.1	8.4	10.9	9.9			10.4	9.7	80	
85	10.8	9.5	8.3	12.4	10.2	8.4	12.5	10.3	8.4	12.4	10.3	8.4	11.1	9.9	8.3	10.6	9.7	8.2		10.2	9.5	85	
90	10.2	9.2	8.1	11.9	9.9	8.3	12	10	8.4	11.9	10.1	8.4	10.8	9.7	8.2	10.4	9.5	8.1		10	9.4	8	90
95	9.6	9	8	11.4	9.7	8.2	11.6	9.8	8.2	11.5	9.9	8.2	10.6	9.5	8.1	10.2	9.4	8		9.8	9.2	7.9	95
100	9.1	8.7	7.9	11	9.5	8.1	11.1	9.6	8.2	11.2	9.7	8.1	10.3	9.3	8	9.9	9.2	7.9		9.6	9	7.8	100
105	8.6	8.3	7.8	10.6	9.3	8	10.8	9.4	8.1	10.8	9.5	8.1	10	9.2	7.9	9.7	9	7.8		9.4	8.9	7.8	105
110	8.1	7.9	7.7	10.2	9.1	7.9	10.4	9.2	8	10.5	9.3	8	9.7	9	7.8	9.5	8.9	7.8		9.2	8.7	7.7	110
115	7.7	7.5	7.5	9.8	8.9	7.9	10.1	9	7.9	10.2	9.1	7.9	9.5	8.8	7.8	9.2	8.7	7.7		9	8.5	7.6	115
120	7.3	7.2	7.2	9.4	8.7	7.8	9.7	8.8	7.8	9.9	9	7.8	9.2	8.6	7.7	9	8.5	7.7		8.8	8.3	7.6	120
125	6.9	6.8	6.9	9.1	8.4	7.7	9.4	8.6	7.7	9.6	8.8	7.7	9	8.4	7.6	8.8	8.2	7.6		8.6	8.1	7.5	125
130	6.6	6.5	6.6	8.7	8.2	7.7	9.1	8.4	7.7	9.3	8.6	7.7	8.7	8.2	7.6	8.6	8	7.5		8.4	7.9	7.5	130
135	6.3	6.3	6.3	8.4	8	7.6	8.7	8.1	7.6	9	8.3	7.6	8.5	7.9	7.5	8.4	7.8	7.4		8.2	7.7	7.4	135
140	6	6	6.1	8.1	7.7	7.5	8.4	7.9	7.5	8.7	8.1	7.5	8.2	7.7	7.4	8.2	7.6	7.3		8	7.5	7.2	140
145	5.7	5.8	5.9	7.8	7.4	7.3	8.2	7.7	7.4	8.4	7.8	7.4	8	7.5	7.2	8	7.5	7.2		7.8	7.4	7.1	145
150	5.5	5.5		7.5	7.2	7.1	7.9	7.5	7.3	8.1	7.6	7.3	7.8	7.3	7.1	7.7	7.3	7.1		7.6	7.2	6.9	150
155				7.3	7	6.9	7.6	7.3	7.1	7.9	7.4	7.2	7.6	7.1	6.9	7.5	7.1	6.9		7.4	7	6.8	155
160				7	6.8	6.7	7.4	7	6.9	7.6	7.2	7	7.4	7	6.8	7.3	6.9	6.7		7.2	6.9	6.7	160
165				6.8	6.6	6.5	7.2	6.8	6.7	7.4	7	6.9	7.1	6.8	6.7	7.1	6.8	6.6		7.1	6.7	6.5	165
170				6.6	6.4	6.4	6.9	6.6	6.6	7.2	6.9	6.7	7	6.6	6.5	7	6.6	6.5		6.9	6.6	6.4	170
175				6.4	6.2	6.2	6.7	6.5	6.4	7	6.7	6.6	6.8	6.5	6.4	6.8	6.5	6.3		6.8	6.4	6.3	175
180				6.2	6	6.1	6.5	6.3	6.3	6.8	6.5	6.4	6.6	6.3	6.3	6.6	6.3	6.2		6.6	6.3	6.2	180
185				6	5.9	6	6.3	6.1	6.2	6.6	6.3	6.3	6.4	6.2	6.2	6.5	6.2	6.1		6.5	6.1	6.1	185
190				5.8	5.7	5.8	6.1	6	6	6.4	6.2	6.1	6.3	6	6	6.3	6	6		6.3	6	6	190
195				5.6	5.6	5.7	6	5.8	5.9	6.2	6	6	6.1	5.9	5.9	6.2	5.9	5.9		6.2	5.9	5.9	195
200				5.5	5.4	5.7	5.8	5.7	5.8	6.1	5.9	5.9	6	5.8	5.8	6	5.8	5.8		6	5.8	5.8	200
205				5.3	5.3	5.6	5.6	5.6	5.7	5.9	5.7	5.8	5.8	5.7	5.7	5.9	5.7	5.7		5.9	5.7	5.7	205
210				5.2	5.3		5.5	5.4	5.6	5.7	5.6	5.7	5.7	5.6	5.6	5.8	5.6	5.6		5.8	5.6	5.6	210
215				5.1	5.2		5.3	5.3	5.6	5.6	5.5	5.6	5.6	5.4	5.5	5.6	5.5	5.6		5.6	5.5	5.5	215
220							5.2	5.2	5.6	5.5	5.4	5.6	5.4	5.3	5.5	5.5	5.4	5.5		5.5	5.4	5.4	220
225							5.1	5.2		5.3	5.3	5.5	5.3	5.2	5.4	5.4	5.3	5.4		5.4	5.3	5.4	225
230							5	5.1		5.2	5.2	5.5	5.2	5.2	5.4	5.3	5.2	5.3		5.3	5.2	5.3	230
235							4.6			5.1	5.1	5.5	5.1	5.1	5.3	5.2	5.1	5.3		5.2	5.1	5.2	235
240										5	5		5	5	5.3	5.1	5	5.2		5.1	5	5.2	240
245										4.8	5		4.9	4.9	5.3	5	5	5.2		5	5	5.1	245
250										3.8			4.9	4.9	5.3	4.9	4.9	5.1		4.9	4.9	5.1	250
255													4.8	4.9		4.8	4.8	5.1		4.5	4.8	5.1	255
260													4.3	4.9		4.8	4.8	5.1		4	4.6	4.9	260
265																4.6	4.7	5.1		3.9	4.1	4.3	265
270																3.7	4.6	4.1		3.8	3.8	4	270
275																3.7	3.8			3.8	3.8	4	275
280																2.7				3.6	3.7	4	280
285																				3.4	3.7	3.7	285
290																				2.9	3.4		290
295																						2.6	295

Lifting capacities

Forces de levage

TVK/TVNZK

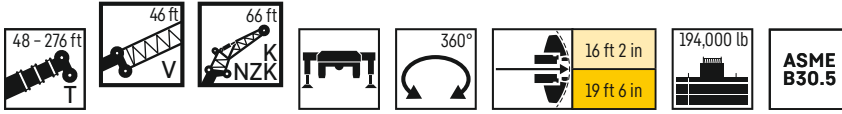

	211 ft + V 46 ft			227 ft + V 46 ft			243 ft + V 46 ft			260 ft + V 46 ft			276 ft + V 46 ft			
	K/NZK 66 ft															
	0°	20°	40°	0°	20°	40°	0°	20°	40°	0°	20°	40°	0°	20°	40°	
50	9.9															50
55	9.8			8.8												55
60	9.7			8.7			7.5									60
65	9.5			8.6			7.5									65
70	9.4			8.5			7.5									70
75	9.2			8.3			7.5									75
80	9.1	8.8		8.2			7.4			5.7						80
85	9	8.7		8.1	7.9		7.3			5.7						85
90	8.8	8.5		8	7.8		7.2	6.9		5.7						90
95	8.6	8.3	7.6	7.9	7.7		7.1	6.9		5.7	5.6					95
100	8.5	8.2	7.5	7.8	7.5	7.2	7	6.8		5.7	5.6			4.4		100
105	8.3	8	7.5	7.6	7.4	7.2	6.9	6.8	6.3	5.7	5.6			4.4		105
110	8.2	7.8	7.4	7.5	7.3	7.1	6.8	6.7	6.3	5.7	5.5			4.4		110
115	8	7.7	7.4	7.4	7.1	7	6.7	6.6	6.3	5.6	5.5	5.3		4.4		115
120	7.9	7.5	7.2	7.3	7	6.8	6.6	6.5	6.3	5.6	5.5	5.3	4.4	4.4	4.3	120
125	7.7	7.4	7	7.2	6.9	6.7	6.5	6.4	6.3	5.6	5.5	5.3	4.4	4.4	4.3	125
130	7.6	7.2	6.9	7	6.8	6.6	6.4	6.3	6.2	5.5	5.5	5.3	4.4	4.4	4.3	130
135	7.4	7	6.7	6.9	6.6	6.5	6.3	6.2	6.1	5.5	5.4	5.3	4.4	4.4	4.3	135
140	7.3	6.8	6.6	6.8	6.5	6.3	6.3	6.1	6	5.4	5.4	5.3	4.4	4.4	4.3	140
145	7.1	6.7	6.4	6.6	6.4	6.2	6.2	6	5.9	5.4	5.3	5.3	4.4	4.4	4.3	145
150	7	6.5	6.3	6.5	6.2	6.1	6.1	5.9	5.8	5.3	5.2	5.2	4.4	4.4	4.3	150
155	6.8	6.3	6.2	6.4	6.1	5.9	6	5.8	5.7	5.2	5.1	5.1	4.4	4.4	4.3	155
160	6.6	6.2	6	6.3	6	5.8	5.9	5.7	5.6	5.1	5	5	4.3	4.4	4.3	160
165	6.4	6.1	5.9	6.2	5.9	5.7	5.8	5.6	5.5	4.9	4.8	4.9	4.3	4.4	4.3	165
170	6.3	5.9	5.8	6	5.7	5.6	5.7	5.5	5.4	4.8	4.7	4.8	4.2	4.4	4.3	170
175	6.1	5.8	5.7	5.9	5.6	5.5	5.6	5.4	5.3	4.7	4.6	4.7	4.1	4.3	4.3	175
180	6	5.7	5.6	5.8	5.5	5.4	5.5	5.3	5.2	4.6	4.5	4.5	4	4.1	4.2	180
185	5.8	5.6	5.5	5.6	5.4	5.3	5.4	5.2	5.1	4.5	4.4	4.5	3.9	4	4.2	185
190	5.7	5.4	5.4	5.5	5.3	5.2	5.3	5.1	5.1	4.4	4.3	4.4	3.7	3.9	4.1	190
195	5.5	5.3	5.3	5.4	5.2	5.1	5.1	5	5	4.3	4.2	4.3	3.6	3.8	4	195
200	5.4	5.2	5.2	5.2	5.1	5	5	4.9	4.9	4.2	4.1	4.2	3.5	3.7	3.9	200
205	5.3	5.1	5.1	5.1	5	5	4.9	4.8	4.8	4.1	4	4.1	3.4	3.6	3.8	205
210	5.1	5	5	5	4.9	4.9	4.8	4.7	4.8	4	4	4	3.3	3.5	3.6	210
215	5	4.9	4.9	4.9	4.8	4.8	4.7	4.6	4.7	3.9	3.9	3.9	3.2	3.3	3.5	215
220	4.9	4.7	4.8	4.8	4.7	4.7	4.6	4.5	4.6	3.8	3.8	3.8	3.1	3.2	3.4	220
225	4.8	4.6	4.7	4.6	4.6	4.6	4.5	4.4	4.5	3.7	3.7	3.7	3	3.1	3.3	225
230	4.6	4.5	4.6	4.5	4.5	4.5	4.4	4.3	4.4	3.6	3.6	3.7	2.9	3	3.2	230
235	4.5	4.4	4.5	4.5	4.4	4.4	4.4	4.3	4.3	3.5	3.5	3.6	2.8	2.9	3.1	235
240	4.4	4.4	4.4	4.4	4.3	4.4	4.2	4.2	4.3	3.4	3.5	3.5	2.7	2.8	3	240
245	4.3	4.3	4.3	4.3	4.2	4.3	4	4.1	4.2	3.3	3.4	3.4	2.6	2.7	2.9	245
250	4.2	4.2	4.3	4.1	4.1	4.2	3.7	4	4.1	3.2	3.3	3.4	2.4	2.6	2.8	250
255	4.1	4.1	4.2	4	4	4.1	3.4	3.8	4	3.1	3.2	3.3	2.3	2.5	2.7	255
260	4	4	4.1	4	3.9	4	3.2	3.6	3.8	2.9	3.2	3.2		2.4	2.6	260
265	3.9	4	4.1	3.9	3.8	4	3.1	3.3	3.5	2.7	3.1	3.2		2.3	2.5	265
270	3.8	3.8	4	3.8	3.8	3.9	3	3	3.2	2.4	2.8	3			2.3	270
275	3.8	3.8	3.9	3.6	3.7	3.9	2.9	3	3.1		2.6	2.8				275
280	3.7	3.7	3.9	3.2	3.6	3.8	2.9	2.9	3		2.3	2.5				280
285	3.5	3.6	3.7	2.9	3.4	3.6	2.8	2.8	2.9							285
290	3.4	3.5	3.5	2.8	3	3.2	2.6	2.8	2.9							290
295	3	3.3	3.2	2.6	2.8	2.9	2.2	2.7	2.8							295
300	2.5	2.9	2.8	2.4	2.6	2.6		2.4	2.6							300
305		2.4		2.2	2.4	2.4										305
310					2.2											310

Lifting heights

Hauteurs de levage

TS

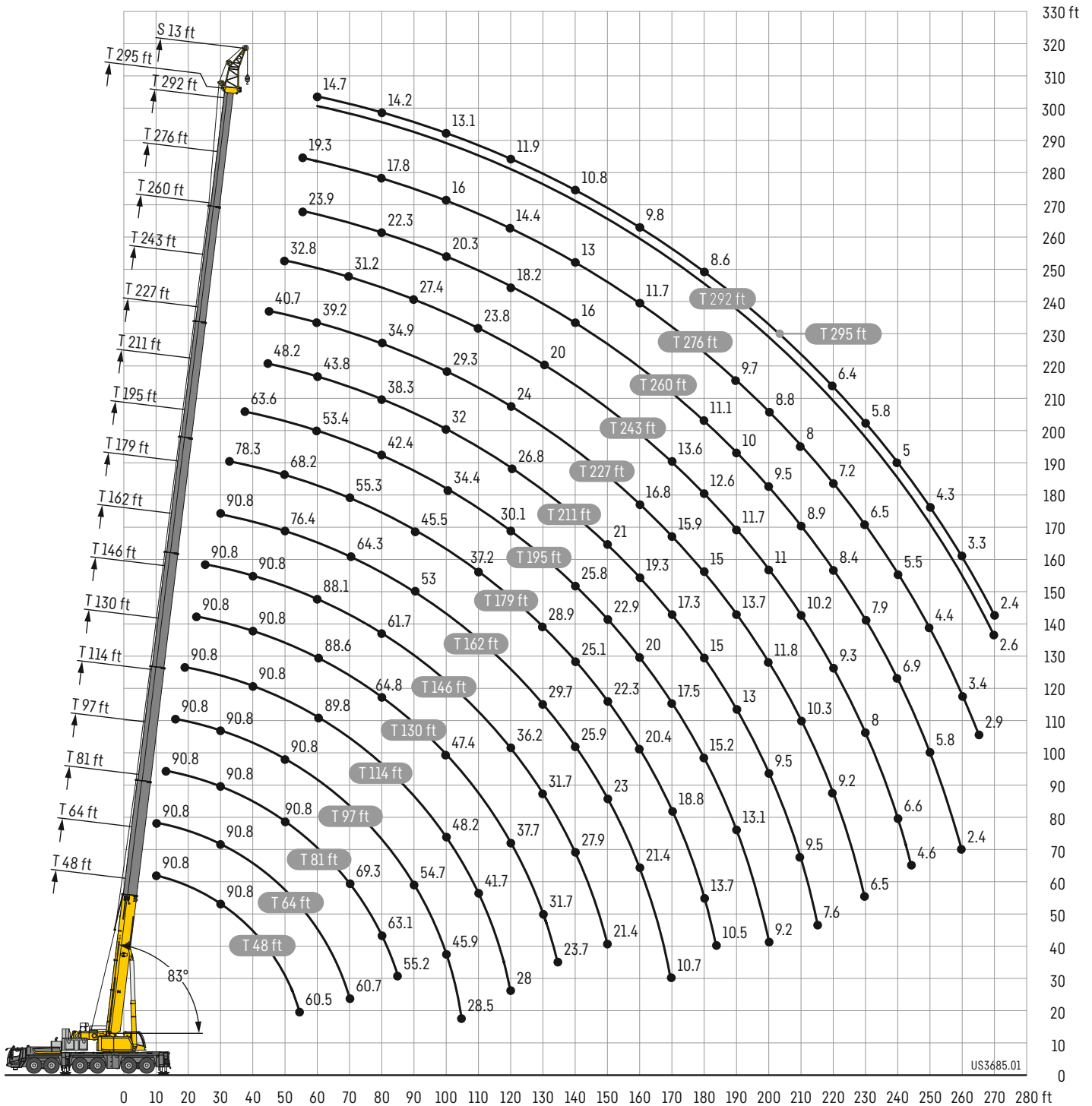

Lifting capacities

Forces de levage

TS 13 ft

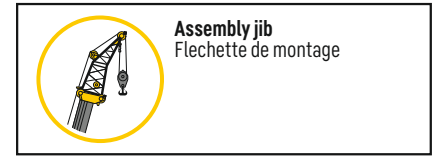
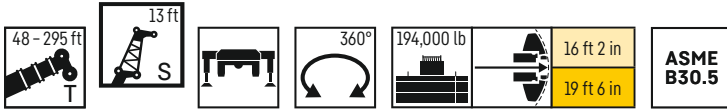

	48 ft	64 ft	81 ft	97 ft	114 ft	130 ft	146 ft	162 ft	179 ft	195 ft	211 ft	227 ft	243 ft	260 ft	276 ft	292 ft	295 ft	
S 13 ft																		
10	90.8	90.8																10
11	90.8	90.8																11
12	90.8	90.8																12
13	90.8	90.8	90.8															13
14	90.8	90.8	90.8															14
15	90.8	90.8	90.8															15
16	90.8	90.8	90.8	90.8														16
17	90.8	90.8	90.8	90.8														17
18	90.8	90.8	90.8	90.8														18
19	90.8	90.8	90.8	90.8	90.8													19
20	90.8	90.8	90.8	90.8	90.8	90.8												20
22	90.8	90.8	90.8	90.8	90.8	90.8	90.8											22
24	90.8	90.8	90.8	90.8	90.8	90.8	90.8	90.8										24
26	90.8	90.8	90.8	90.8	90.8	90.8	90.8	90.8	90.8									26
28	90.8	90.8	90.8	90.8	90.8	90.8	90.8	90.8	90.8	90.8								28
30	90.8	90.8	90.8	90.8	90.8	90.8	90.8	90.8	90.8	90.8	90.8							30
32	90.8	90.8	90.8	90.8	90.8	90.8	90.8	90.8	90									32
34	90.8	90.8	90.8	90.8	90.8	90.8	90.8	90.8	88.6	78.3								34
36	90.8	90.8	90.8	90.8	90.8	90.8	90.8	90.8	87	78.3								36
38	90.2	90.8	90.8	90.8	90.8	90.8	90.8	90.8	85.3	77.1	63.6							38
40	86.5	90.8	90.8	90.8	90.8	90.8	90.8	90.8	83.7	75.7	63.6							40
45	69.3	90.8	90.8	90.8	90.8	90.8	90.8	90.8	79.8	71.7	62.9	48.2	40.7					45
50	64.2	87.5	90.8	90.8	90.8	90.8	90.8	90.8	76.4	68.2	60.1	46.6	40.7	32.8				50
55	60.5	73.1	89.9	90.8	90.8	90.8	90.6	73.3	64.6	56.5	45.2	40.1	32.8	23.9	19.3			55
60		67.2	85.9	90.6	89.8	88.6	88.1	70.1	61.3	53.4	43.8	39.2	32.6	23.7	19.2	15.1	14.7	60
65		63.5	78.3	86.1	84.1	83.5	80.1	67.1	58.1	50.3	42.4	38.2	31.9	23.4	18.9	15	14.7	65
70		60.7	69.3	78	76.5	77	73.2	64.3	55.3	47.6	41.2	37.1	31.2	23.1	18.5	14.9	14.5	70
75			65.9	70.9	70.3	70.6	67	61.7	52.5	44.9	39.8	36	30.2	22.7	18.1	14.7	14.4	75
80			63.1	64.8	66.1	64.8	61.7	59.3	50.1	42.4	38.3	34.9	29.3	22.3	17.8	14.5	14.2	80
85			55.2	59.4	60.9	59.5	57.1	56.7	47.8	39.8	36.8	33.6	28.3	21.8	17.3	14.2	13.9	85
90				54.7	56.1	54.6	52.8	53	45.5	37.7	35.2	32.2	27.4	21.3	16.9	13.9	13.6	90
95				51.7	51.9	50.5	50.5	49.5	43.2	35.6	33.6	30.7	26.5	20.8	16.5	13.6	13.4	95
100				45.9	48.2	47.4	47.9	46.1	41.1	34.4	32	29.3	25.6	20.3	16	13.3	13.1	100
105				28.5	44.8	44.2	44.7	42.8	39	33.2	30.4	27.9	24.7	19.8	15.6	12.9	12.7	105
110					41.7	41.5	41.5	39.6	37.2	32.2	29.1	26.6	23.8	19.2	15.2	12.6	12.5	110
115					36.6	39.9	38.7	36.8	35.4	31.1	27.9	25.3	22.9	18.7	14.8	12.4	12.2	115
120					28	37.7	36.2	34.2	33.4	30.1	26.8	24	22	18.2	14.4	12.1	11.9	120
125						35.4	33.9	31.9	31.1	29.1	25.7	22.8	21	17.6	14	11.8	11.6	125
130						31.7	31.7	29.7	28.9	28	24.7	21.6	20	17.1	13.7	11.5	11.4	130
135						23.7	29.7	27.8	27	26.9	23.8	20.4	19	16.5	13.3	11.2	11.1	135
140							27.9	25.9	25.1	25.8	22.8	19.4	18	16	13	10.9	10.8	140
145							24.7	24.4	23.4	24.5	21.9	18.7	17	15.5	12.6	10.6	10.6	145
150								21.4	23	22.3	22.9	21	17.9	16.1	15	12.3	10.4	150
155									22.1	21.3	21.4	20.1	17.3	15.2	14.5	12	10.1	155
160									21.4	20.4	20	19.3	16.8	14.6	13.9	11.7	9.9	160
165									17.1	19.6	18.7	18.5	16.4	14.1	13.1	11.4	9.6	165
170									10.7	18.8	17.5	17.3	15.9	13.6	12.4	11.1	9.3	170
175										16.5	16.3	16.1	15.5	13.1	11.7	10.7	8.9	175
180										13.7	15.2	15	15	12.6	11.1	10.4	8.7	180
185										10.5	14.3	14	14.4	12.1	10.6	10	8.4	185
190											13.1	13	13.7	11.7	10	9.7	8.1	190
195											11.9	12.3	12.7	11.3	9.7	9.2	7.8	195
200											9.2	11.9	11.8	11	9.5	8.8	7.5	200
205												11.4	11	10.7	9.2	8.4	7.2	205
210												9.5	10.3	10.2	8.9	8	7	210
215												7.6	9.7	9.9	8.7	7.6	6.8	215
220													9.2	9.3	8.4	7.2	6.5	220
225													7.9	8.6	8.2	6.9	6.3	225
230													6.5	8	7.9	6.5	5.9	230
235														7.5	7.5	6	5.6	235
240														6.6	6.9	5.5	5.3	240
245														4.6	6.4	5	4.9	245
250															5.8	4.4	4.5	250
255															4.5	3.9	4	255
260															2.4	3.4	3.6	260
265																2.9	3.1	265
270																	2.6	270

Lifting heights

Hauteurs de levage

TS

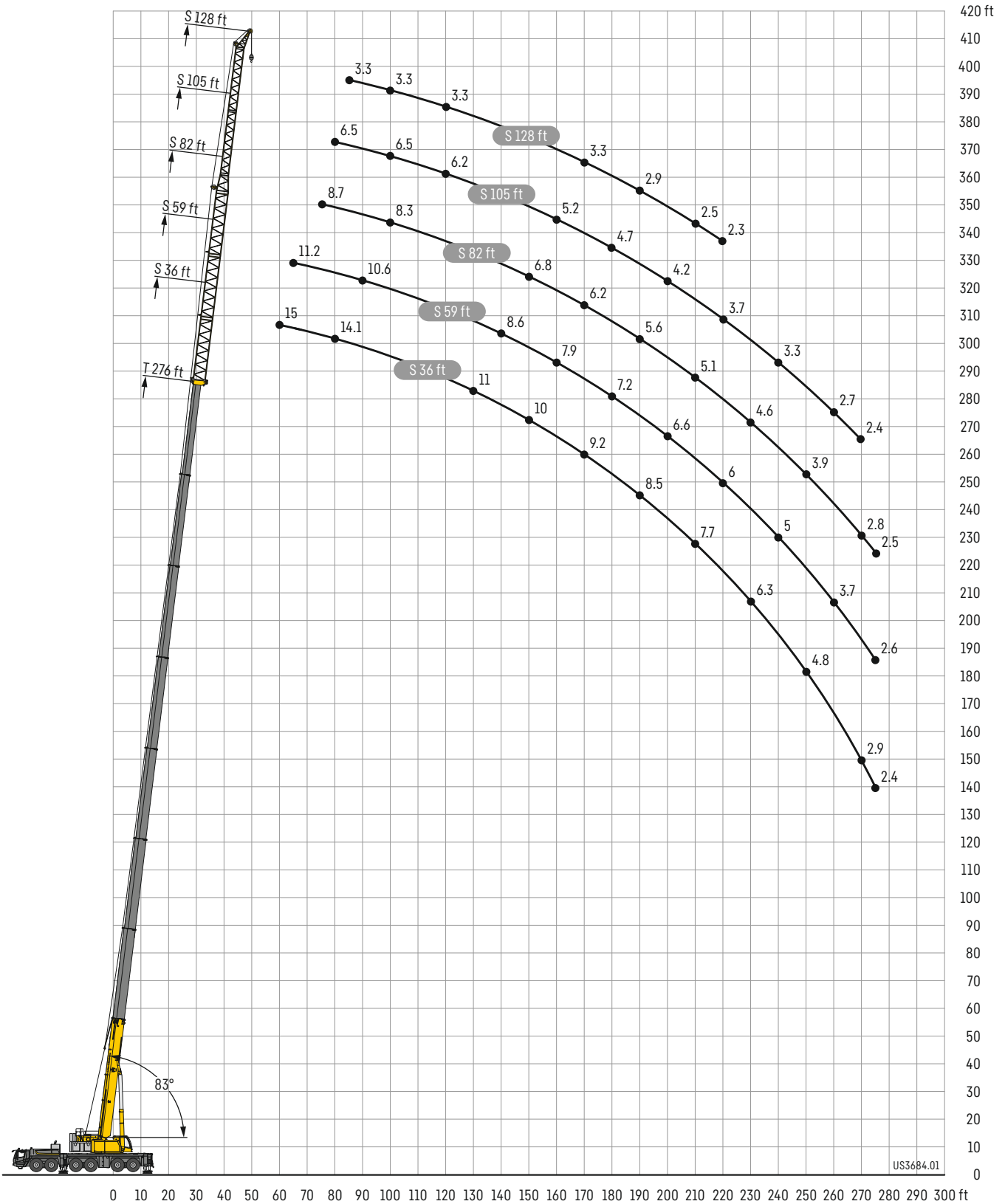

Lifting capacities

Forces de levage

TS 36 ft

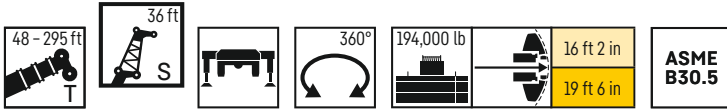

	48 ft	114 ft	130 ft	146 ft	162 ft	179 ft	195 ft	211 ft	227 ft	243 ft	260 ft	276 ft	292 ft	295 ft	
S 36 ft															
12	90.8														12
13	90.1														13
14	87.6														14
15	85.1														15
16	82.5														16
17	80.2														17
18	77.7														18
19	75.7														19
20	73.8														20
22	68.9	76													22
24	64	74													24
26	59.6	71.9	71.3												26
28	55.4	69.7	69.3	67.4											28
30	52.2	67.2	67.1	65.7											30
32	48.9	64.7	64.9	63.7	55.7										32
34	46	62.4	62.8	62.1	54.4										34
36	43.7	60.1	60.9	60.3	53.3	50									36
38	41.2	58.1	59.1	58.7	52.1	49.1									38
40	39	56.2	57.4	57	51	48.4	38.2								40
45	34.4	52	53	53.5	48.3	46.3	43.5	34.6							45
50	30.7	48	49.6	50.1	46	44.3	42	33.5	30.2						50
55	27.6	44.4	46.6	47.3	43.8	42.6	40.6	32.4	29.5	23.8	18.4				55
60	25	41.2	43.6	44.7	41.8	40.9	39.2	31.4	28.8	23.6	18.2	15			60
65	22.8	38.4	40.9	42.4	39.9	39.3	37.9	30.4	27.9	23.3	18	14.8	11.7	11.4	65
70	20.9	36	38.4	40.1	38.1	37.8	36.6	29.3	27.1	22.8	17.7	14.6	11.6	11.3	70
75	19.2	33.5	36.1	37.8	36.2	36.3	35.4	28.3	26.2	22.4	17.4	14.4	11.5	11.3	75
80		31.5	34	35.8	34.5	34.8	34.1	27.3	25.4	22	17.1	14.1	11.4	11.1	80
85		29.7	32.1	34	33	33.4	32.9	26.3	24.6	21.6	16.8	13.8	11.2	11	85
90		28	30.4	32.2	31.6	32.1	31.7	25.4	23.8	21.1	16.4	13.5	11	10.8	90
95		26.5	28.8	30.7	30.3	30.8	30.6	24.5	23.1	20.6	16.1	13.1	10.8	10.6	95
100		25.2	27.4	29.3	29	29.7	29.5	23.7	22.5	20.1	15.7	12.8	10.6	10.5	100
105		24	26.1	27.8	27.8	28.6	28.6	22.9	21.8	19.6	15.3	12.5	10.4	10.3	105
110		22.9	24.9	26.7	26.8	27.5	27.6	22.2	21.2	19.1	14.9	12.2	10.2	10.1	110
115		21.9	23.9	25.5	25.7	26.6	26.4	21.5	20.5	18.5	14.5	11.8	10	9.9	115
120		21	22.9	24.5	24.8	25.7	25.4	20.9	20	18	14.2	11.5	9.8	9.7	120
125		20.1	22	23.6	24	24.9	24.2	20.2	19.5	17.5	13.8	11.2	9.7	9.6	125
130		19.3	21.1	22.7	23.1	24.1	23.1	19.6	18.9	17	13.5	11	9.5	9.4	130
135		18.7	20.4	22	22.4	23.4	21.8	19	18.3	16.4	13.2	10.7	9.3	9.2	135
140		18.1	19.7	21.2	21.7	22.7	20.5	18.5	17.7	15.9	12.9	10.5	9.1	9	140
145			19	20.5	21.1	22	19.4	17.9	17.1	15.3	12.5	10.2	8.9	8.8	145
150			18.4	19.8	20.5	21.4	18.2	17.3	16.4	14.8	12.2	10	8.7	8.7	150
155			18	19.2	19.9	20.9	17.1	16.7	15.6	14.2	12	9.8	8.5	8.5	155
160			13.8	18.7	19.4	20.1	16.4	16.3	14.7	13.7	11.7	9.6	8.4	8.3	160
165				18	18.9	18.9	16	15.9	13.8	13.1	11.4	9.4	8.2	8.1	165
170				17.1	18.4	17.6	15.6	15.6	13.3	12.4	11.1	9.2	8	8	170
175				13.4	17.5	16.4	15.2	15.2	12.8	11.6	10.8	9	7.8	7.8	175
180					15.9	15.3	14.9	14.7	12.4	11	10.4	8.9	7.6	7.6	180
185					13.6	14.3	14.5	14.1	11.9	10.4	10.1	8.7	7.4	7.4	185
190					11	13.9	14.1	13.6	11.5	10.1	9.7	8.5	7.2	7.1	190
195						13.5	13.3	12.8	11.1	9.9	9.3	8.3	7	6.9	195
200						11.7	12.4	11.9	10.8	9.6	8.9	8.1	6.8	6.7	200
205						9.4	11.6	11	10.4	9.3	8.5	7.9	6.5	6.5	205
210							10.6	10.4	10.1	9.1	8	7.7	6.3	6.3	210
215							9.6	9.7	9.8	8.8	7.7	7.4	6.1	6.1	215
220							8.5	9.4	9.7	8.6	7.4	7	5.9	5.8	220
225							5.4	9.1	9.1	8.3	7.2	6.7	5.6	5.6	225
230								8.3	8.4	8.1	7	6.3	5.4	5.3	230
235								6.9	7.8	7.7	6.8	5.9	5.1	5	235
240								4.6	7.2	7.1	6.6	5.6	4.9	4.7	240
245									6.7	6.9	6.4	5.2	4.6	4.4	245
250									5.7	6.3	6.1	4.8	4.3	4.1	250
255									3.5	5.8	5.7	4.3	4	3.7	255
260										5.5	5.2	3.8	3.7	3.4	260
265										4	4.7	3.4	3.4	3.1	265
270											4.3	2.9	3	2.7	270
275											3.3	2.4	2.5	2.3	275

Lifting capacities

Forces de levage

TS 59 ft

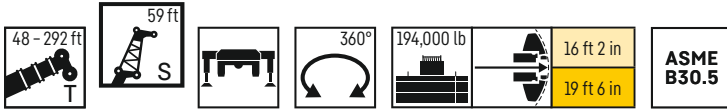

	48 ft	114 ft	130 ft	146 ft	162 ft	179 ft	195 ft	211 ft	227 ft	243 ft	260 ft	276 ft	292 ft	
	S 59 ft													
15	63.4													15
16	61.8													16
17	60													17
18	58.4													18
19	56.8													19
20	55.5													20
22	52.8													22
24	50.2													24
26	47.9	50.2												26
28	45.7	48.8	48											28
30	43.8	47.5	46.9											30
32	42.1	46.4	45.8	44.6										32
34	40.3	45.3	44.9	43.7										34
36	38.7	44.1	43.9	42.8	37.9									36
38	37.1	43	42.8	42	37.4									38
40	35.6	41.9	41.9	41.2	36.7	34.4								40
45	32.3	39.3	39.7	39.3	35.3	33	30.7							45
50	29.1	36.9	37.6	37.4	33.8	31.9	29.8	24.6						50
55	26.3	34.7	35.5	35.5	32.3	30.7	28.9	24	21.1					55
60	24	32.7	33.6	33.9	31	29.7	28	23.4	20.7	17.8				60
65	22.1	30.8	31.9	32.3	29.7	28.5	27.2	22.7	20.3	17.6	13.7	11.2		65
70	20.4	29.3	30.2	30.8	28.5	27.6	26.4	22	19.7	17.3	13.5	11.2		70
75	18.8	27.8	28.8	29.4	27.4	26.7	25.6	21.1	19.2	17	13.3	11.1	9.1	75
80	17.5	26.5	27.5	28.2	26.4	25.8	24.8	20.3	18.6	16.6	13	11	9.1	80
85	16.4	25.2	26.3	27	25.3	24.9	24.1	19.5	18	16.2	12.8	10.8	9	85
90	15.3	23.9	25.2	25.8	24.3	24.1	23.4	18.9	17.4	15.8	12.5	10.6	8.9	90
95	14.4	22.8	24.1	24.9	23.4	23.2	22.8	18.2	16.9	15.4	12.2	10.4	8.8	95
100	13.7	21.6	23.1	23.9	22.5	22.5	22.1	17.6	16.4	15	11.9	10.2	8.6	100
105		20.7	22.1	23.1	21.7	21.7	21.5	17	15.8	14.6	11.6	10	8.5	105
110		19.7	21.1	22.2	20.9	21	20.9	16.4	15.4	14.2	11.3	9.8	8.3	110
115		18.9	20.2	21.4	20.2	20.4	20.3	15.8	14.9	13.9	11	9.6	8.2	115
120		18.1	19.4	20.5	19.5	19.7	19.7	15.3	14.5	13.5	10.8	9.4	8	120
125		17.3	18.6	19.8	18.9	19.1	19.2	14.7	14	13.2	10.6	9.2	7.8	125
130		16.7	18	19.1	18.3	18.6	18.7	14.3	13.6	12.8	10.3	9	7.7	130
135		16	17.3	18.4	17.7	18	18.1	13.8	13.2	12.5	10.1	8.8	7.5	135
140		15.5	16.7	17.8	17.2	17.5	17.6	13.4	12.9	12.2	9.9	8.6	7.4	140
145		15	16.1	17.2	16.7	17	17.1	13	12.5	11.9	9.7	8.4	7.2	145
150		14.5	15.6	16.6	16.2	16.6	16.6	12.6	12.2	11.6	9.5	8.2	7.1	150
155		14	15.1	16.1	15.7	16.1	16.1	12.2	11.9	11.3	9.3	8.1	6.9	155
160		13.7	14.7	15.6	15.3	15.7	15.5	11.9	11.6	11.1	9.1	7.9	6.8	160
165		13.4	14.3	15.2	14.8	15.3	14.8	11.6	11.3	10.9	8.9	7.7	6.6	165
170			13.9	14.8	14.4	14.9	13.9	11.2	11	10.7	8.8	7.5	6.5	170
175			13.6	14.4	14	14.5	13.1	11	10.8	10.5	8.6	7.3	6.4	175
180			12.4	14.1	13.6	14.1	12.4	10.8	10.6	10.2	8.4	7.2	6.2	180
185				13.7	13.3	13.8	11.7	10.5	10.3	9.8	8.3	7	6.1	185
190				12.5	13	13.5	10.9	10.3	9.4	9.4	8.1	6.9	5.9	190
195				11	12.8	13	10.4	10	9.7	9.1	8	6.7	5.7	195
200					12.5	12.1	9.8	9.8	9.4	8.7	7.8	6.6	5.6	200
205					10.8	11.3	9.5	9.6	9.1	8.3	7.6	6.4	5.4	205
210					8.8	10.6	9.3	9.4	8.9	7.8	7.5	6.3	5.2	210
215					6.9	9.6	9.2	9.3	8.6	7.5	7.2	6.2	5	215
220						8.8	9	9.1	8.3	7.3	6.9	6	4.8	220
225						8.1	8.9	8.9	8.1	7.1	6.5	5.9	4.6	225
230						6.6	8.6	8.3	7.9	7	6.2	5.7	4.4	230
235							7.8	7.7	7.6	6.8	5.8	5.4	4.1	235
240							6.8	7.1	6.9	6.6	5.6	5	3.9	240
245							5.3	6.7	6.8	6.4	5.4	4.7	3.7	245
250								6.7	6.4	6.1	5.3	4.3	3.5	250
255								5.5	5.9	5.7	5.2	4	3.3	255
260								4.2	5.6	5.2	5	3.7	3.1	260
265									5.3	5	4.7	3.4	2.9	265
270									4.2	4.5	4.4	3	2.6	270
275									3.2	4.3	3.9	2.6	2.3	275
280										4.1	3.5			280
285										2.9	3.1			285
290											2.7			290

Lifting capacities

Forces de levage

TS 82 ft

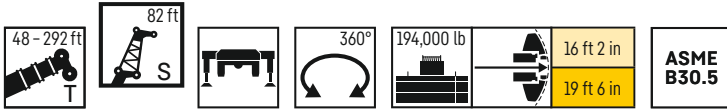

	48 ft	114 ft	130 ft	146 ft	162 ft	179 ft	195 ft	211 ft	227 ft	243 ft	260 ft	276 ft	292 ft	
	S 82 ft													
19	44.4													19
20	43.3													20
22	41.5													22
24	39.8													24
26	38.1													26
28	36.6													28
30	35.1	35.3												30
32	33.7	34.4	34											32
34	32.4	33.6	33.2											34
36	31.1	32.8	32.5	31.6										36
38	29.9	32.1	31.8	31										38
40	28.8	31.3	31.2	30.4	27									40
45	26.1	29.5	29.5	29	25.8	23.9								45
50	23.8	27.7	28	27.7	24.7	23.1	21.5							50
55	21.7	26.1	26.5	26.4	23.6	22.3	20.9	17.6						55
60	19.8	24.4	25	25.1	22.6	21.5	20.3	17.2	15.1					60
65	18.1	23.2	23.6	23.8	21.7	20.8	19.6	16.8	14.8	12.8				65
70	16.6	21.9	22.5	22.6	20.8	20	19.1	16.4	14.6	12.6	10.4			70
75	15.3	20.7	21.3	21.6	19.9	19.3	18.5	16	14.3	12.4	10.3	8.7		75
80	14.1	19.6	20.3	20.6	19.1	18.6	17.9	15.6	14	12.2	10.1	8.7	6.7	80
85	13.1	18.5	19.3	19.7	18.4	17.9	17.3	15.2	13.7	12	10	8.6	6.7	85
90	12.2	17.6	18.4	18.8	17.6	17.4	16.8	14.6	13.4	11.9	9.8	8.6	6.7	90
95	11.4	16.7	17.5	18	17	16.8	16.3	14.1	13	11.7	9.7	8.5	6.7	95
100	10.7	15.8	16.7	17.2	16.4	16.3	15.8	13.6	12.5	11.4	9.5	8.3	6.7	100
105	10.2	15.1	15.9	16.5	15.7	15.7	15.4	13.1	12.1	11.1	9.3	8.2	6.7	105
110	9.7	14.3	15.2	15.8	15.1	15.2	14.9	12.6	11.8	10.8	9.1	8.1	6.7	110
115	9.2	13.6	14.5	15.1	14.6	14.8	14.5	12.1	11.4	10.6	8.9	7.9	6.6	115
120	8.9	13	13.9	14.4	14.1	14.3	14.1	11.7	11.1	10.4	8.7	7.7	6.5	120
125	8.6	12.3	13.2	13.8	13.6	13.8	13.7	11.4	10.8	10.2	8.5	7.6	6.4	125
130		11.8	12.7	13.3	13.1	13.4	13.3	11	10.5	9.9	8.3	7.4	6.2	130
135		11.3	12.1	12.7	12.6	12.9	12.9	10.7	10.2	9.7	8.2	7.3	6.1	135
140		10.9	11.6	12.2	12.2	12.5	12.5	10.4	10	9.5	8	7.1	6	140
145		10.5	11.2	11.8	11.8	12.1	12.2	10.1	9.7	9.3	7.8	6.9	5.9	145
150		10.2	10.8	11.3	11.4	11.8	11.8	9.9	9.5	9.1	7.6	6.8	5.8	150
155		9.9	10.5	11	11.2	11.4	11.5	9.6	9.3	8.9	7.5	6.6	5.6	155
160		9.6	10.2	10.6	10.8	11.1	11.3	9.3	9.1	8.7	7.3	6.5	5.5	160
165		9.3	9.8	10.3	10.5	10.8	11	9.1	8.9	8.5	7.1	6.3	5.4	165
170		9	9.6	10.1	10.3	10.6	10.7	8.9	8.7	8.4	7	6.2	5.3	170
175		8.8	9.3	9.8	10.1	10.3	10.5	8.7	8.5	8.2	6.9	6	5.1	175
180		8.6	9.1	9.5	9.8	10.1	10.3	8.4	8.3	8.1	6.7	5.9	5	180
185		8.4	8.9	9.3	9.6	9.9	10.1	8.2	8.1	7.9	6.6	5.8	4.9	185
190		8.3	8.6	9	9.4	9.7	9.9	8	7.9	7.7	6.4	5.6	4.8	190
195			8.5	8.8	9.3	9.5	9.7	7.9	7.8	7.6	6.3	5.5	4.7	195
200			8.3	8.7	9.1	9.4	9.4	7.7	7.6	7.4	6.2	5.4	4.6	200
205			8.2	8.5	8.9	9.2	9.1	7.6	7.5	7.3	6	5.2	4.4	205
210				8.4	8.8	9.1	8.8	7.4	7.3	7.1	5.9	5.1	4.3	210
215				8.2	8.7	8.9	8.5	7.3	7.2	6.9	5.8	5	4.1	215
220				6.8	8.5	8.8	8.1	7.1	7.1	6.7	5.7	4.9	3.9	220
225					8.4	8.6	7.6	6.9	6.8	6.4	5.6	4.7	3.7	225
230					7.6	8.5	7.1	6.8	6.7	6	5.5	4.6	3.5	230
235					6.2	8.1	6.5	6.6	6.6	5.6	5.3	4.4	3.3	235
240						6.8	6.4	6.5	6.5	5.3	5	4.3	3.1	240
245						6.2	6.3	6.4	6.3	5.2	4.7	4.2	2.9	245
250						5.1	6.3	6.3	6.1	5.1	4.4	3.9	2.7	250
255							6.1	5.9	5.7	5.1	4.1	3.7	2.5	255
260							5.2	5.5	5.1	5	4	3.4	2.4	260
265							4.7	5.3	4.9	4.8	3.9	3.1		265
270							3	4.9	4.7	4.5	3.8	2.8		270
275								4.6	4.4	4	3.6	2.5		275
280								3.5	4.3	3.6	3.5			280
285									3.9	3.4	3.2			285
290									3.1	3.1	2.8			290
295									2.5	2.9	2.5			295
300										2.7				300

Lifting capacities

Forces de levage

TS 105 ft

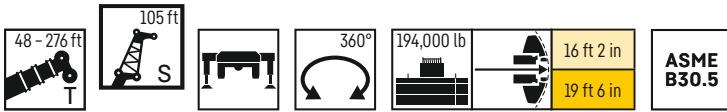

	48 ft	114 ft	130 ft	146 ft	162 ft	179 ft	195 ft	211 ft	227 ft	243 ft	260 ft	276 ft	
	S 105 ft												
24	31.1												24
26	30.2												26
28	29.1												28
30	28												30
32	27.2												32
34	26.2	25.6											34
36	25.2	25.1	24.6										36
38	24.4	24.4	24.1	23.5									38
40	23.4	23.9	23.6	23									40
45	21.3	22.6	22.5	22	19								45
50	19.5	21.2	21.3	21	18.3	17.1							50
55	17.9	20.1	20.2	20	17.6	16.5	15.4						55
60	16.4	18.9	19.1	19	16.9	15.9	14.9	12.5	11				60
65	15.1	17.9	18.1	18.1	16.2	15.4	14.5	12.2	10.8				65
70	13.8	16.9	17.2	17.2	15.5	14.8	14	11.9	10.6	9.4			70
75	12.6	16	16.4	16.4	14.9	14.3	13.5	11.6	10.4	9.3	7.9		75
80	11.7	15.2	15.6	15.7	14.3	13.8	13.1	11.3	10.2	9.1	7.8	6.5	80
85	10.9	14.4	14.8	15	13.8	13.3	12.7	11	10.1	9	7.7	6.5	85
90	10.1	13.7	14.1	14.4	13.2	12.8	12.3	10.8	9.9	8.9	7.6	6.5	90
95	9.6	13	13.4	13.7	12.7	12.3	11.9	10.5	9.7	8.8	7.6	6.5	95
100	9	12.4	12.8	13.1	12.2	11.9	11.5	10.3	9.5	8.6	7.5	6.5	100
105	8.5	11.8	12.2	12.5	11.8	11.5	11.2	10.1	9.4	8.5	7.4	6.4	105
110	8.1	11.3	11.7	12	11.3	11.1	10.9	9.8	9.2	8.4	7.3	6.3	110
115	7.7	10.8	11.2	11.5	11	10.8	10.6	9.6	9	8.3	7.2	6.3	115
120	7.3	10.3	10.8	11.1	10.6	10.5	10.3	9.4	8.8	8.1	7	6.2	120
125	6.9	9.9	10.4	10.7	10.3	10.2	10.1	9.1	8.7	8	6.9	6.1	125
130	6.6	9.5	10	10.3	10	9.9	9.8	8.9	8.4	7.9	6.7	6	130
135	6.3	9.1	9.6	10	9.7	9.7	9.5	8.6	8.2	7.7	6.6	5.9	135
140	6.1	8.8	9.2	9.6	9.4	9.4	9.3	8.3	8	7.6	6.4	5.8	140
145	5.8	8.4	8.9	9.3	9.1	9.1	9.1	8.1	7.8	7.4	6.3	5.6	145
150		8.2	8.6	9	8.8	8.9	8.8	7.9	7.6	7.2	6.1	5.5	150
155		7.9	8.3	8.7	8.5	8.6	8.6	7.7	7.4	7	6	5.3	155
160		7.6	8.1	8.4	8.3	8.4	8.4	7.5	7.2	6.9	5.8	5.2	160
165		7.3	7.8	8.1	8.1	8.2	8.2	7.3	7	6.7	5.7	5.1	165
170		7.1	7.5	7.9	7.8	7.9	8	7.1	6.9	6.6	5.5	4.9	170
175		6.9	7.3	7.6	7.6	7.7	7.8	6.9	6.7	6.4	5.4	4.8	175
180		6.6	7	7.4	7.4	7.5	7.6	6.7	6.5	6.3	5.3	4.7	180
185		6.4	6.8	7.2	7.2	7.4	7.4	6.5	6.4	6.1	5.2	4.5	185
190		6.3	6.6	7	7	7.2	7.2	6.4	6.2	6	5	4.4	190
195		6.1	6.5	6.8	6.9	7	7.1	6.2	6.1	5.9	4.9	4.3	195
200		5.9	6.3	6.6	6.7	6.8	6.9	6	5.9	5.8	4.8	4.2	200
205		5.8	6.1	6.5	6.6	6.7	6.7	5.9	5.8	5.7	4.7	4.1	205
210		5.7	6	6.3	6.4	6.5	6.6	5.7	5.6	5.5	4.6	3.9	210
215			5.9	6.1	6.3	6.4	6.5	5.6	5.5	5.4	4.5	3.8	215
220			5.7	6	6.1	6.2	6.3	5.5	5.4	5.3	4.4	3.7	220
225			5.6	5.9	6	6.1	6.2	5.3	5.3	5.2	4.3	3.6	225
230				5.7	5.9	6	6.1	5.2	5.2	5.1	4.2	3.5	230
235				5.6	5.8	5.9	6	5.1	5.1	5	4.1	3.4	235
240				5.5	5.7	5.8	5.9	5	5	4.8	4	3.3	240
245				4.3	5.6	5.7	5.7	4.9	4.9	4.5	3.9	3.1	245
250					5.5	5.6	5.2	4.8	4.7	4.2	3.8	3	250
255					4.7	5.5	4.7	4.7	4.6	3.8	3.6	2.8	255
260					4	5.3	4.5	4.5	4.5	3.7	3.4	2.7	260
265						4.3	4.4	4.4	4.5	3.6	3.1	2.5	265
270						4.2	4.3	4.4	4.3	3.5	2.8	2.4	270
275						3.2	4.2	4.2	4	3.5	2.6		275
280							4	4.1	3.5	3.4	2.5		280
285							3.5	4	3.3	3.2	2.4		285
290							2.3	3.6	3.2	2.9	2.3		290
295								3.1	3	2.5			295
300								2.6	2.8	2.2			300
305									2.6				305

Lifting capacities

Forces de levage

TS 128 ft

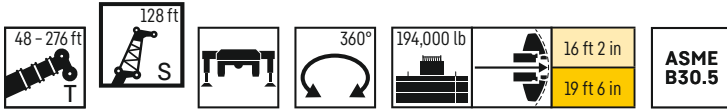

	48 ft	114 ft	130 ft	146 ft	162 ft	179 ft	195 ft	211 ft	227 ft	243 ft	260 ft	276 ft	
	S 128 ft												
26	24.1												26
28	23.5												28
30	22.9												30
32	22.2												32
34	21.5												34
36	20.8												36
38	20.1	19.3											38
40	19.4	18.9	18.6										40
45	17.8	17.9	17.7	17.2									45
50	16.4	16.9	16.8	16.4	14								50
55	15.1	15.9	15.9	15.6	13.4	12.5	11.6						55
60	13.9	15.1	15.1	14.9	12.9	12.1	11.2	9.6					60
65	12.8	14.2	14.3	14.2	12.4	11.6	10.9	9.4					65
70	11.8	13.4	13.6	13.4	11.9	11.2	10.6	9.2	8.2				70
75	11	12.7	12.8	12.8	11.4	10.9	10.4	9	8	7.1			75
80	10.3	12	12.2	12.2	10.9	10.5	10.1	8.8	7.9	7	5.6		80
85	9.6	11.4	11.6	11.6	10.6	10.2	9.8	8.6	7.7	6.9	5.6	3.3	85
90	9	10.8	11.1	11.1	10.2	9.8	9.5	8.4	7.6	6.8	5.6	3.3	90
95	8.5	10.3	10.5	10.7	9.9	9.6	9.2	8.2	7.4	6.6	5.6	3.3	95
100	8	9.9	10.1	10.3	9.5	9.3	9	8	7.3	6.5	5.5	3.3	100
105	7.5	9.4	9.7	9.8	9.3	9	8.7	7.8	7.1	6.4	5.5	3.3	105
110	7.1	9	9.3	9.5	8.9	8.7	8.5	7.6	7	6.3	5.4	3.3	110
115	6.7	8.6	8.9	9.1	8.6	8.4	8.2	7.4	6.8	6.2	5.3	3.3	115
120	6.3	8.2	8.6	8.7	8.3	8.2	8	7.2	6.7	6.1	5.3	3.3	120
125	5.9	7.8	8.2	8.4	8	7.9	7.8	7	6.5	6	5.1	3.3	125
130	5.6	7.5	7.9	8.1	7.7	7.6	7.5	6.8	6.4	5.8	5	3.3	130
135	5.3	7.2	7.5	7.8	7.5	7.4	7.3	6.7	6.2	5.7	4.9	3.3	135
140	5	6.8	7.2	7.5	7.2	7.2	7.1	6.5	6.1	5.6	4.7	3.3	140
145	4.8	6.6	7	7.2	7	7	6.8	6.3	5.9	5.5	4.6	3.3	145
150	4.5	6.3	6.7	6.9	6.7	6.7	6.6	6.1	5.8	5.4	4.5	3.3	150
155	4.3	6	6.4	6.7	6.5	6.5	6.5	6	5.7	5.3	4.3	3.3	155
160	4.1	5.8	6.2	6.4	6.3	6.3	6.3	5.8	5.5	5.2	4.2	3.3	160
165	3.9	5.6	5.9	6.2	6.1	6.1	6.1	5.6	5.4	5.1	4.1	3.3	165
170	3.7	5.4	5.7	6	5.9	5.9	5.9	5.5	5.3	4.9	4	3.3	170
175		5.2	5.5	5.8	5.7	5.7	5.7	5.3	5.2	4.8	3.9	3.3	175
180		5	5.3	5.6	5.5	5.6	5.6	5.2	5	4.7	3.8	3.2	180
185		4.8	5.1	5.4	5.4	5.4	5.4	5	4.9	4.6	3.7	3.1	185
190		4.6	5	5.2	5.2	5.2	5.3	4.9	4.8	4.5	3.5	2.9	190
195		4.5	4.8	5	5	5.1	5.2	4.7	4.7	4.4	3.4	2.8	195
200		4.3	4.6	4.8	4.9	4.9	5	4.6	4.5	4.3	3.3	2.7	200
205		4.2	4.4	4.7	4.7	4.8	4.9	4.5	4.4	4.2	3.2	2.6	205
210		4	4.3	4.6	4.6	4.7	4.7	4.3	4.3	4.1	3.1	2.5	210
215		3.9	4.2	4.4	4.5	4.6	4.6	4.2	4.1	4	3	2.4	215
220		3.8	4.1	4.3	4.3	4.4	4.5	4.1	4	3.9	2.9	2.3	220
225		3.7	3.9	4.2	4.2	4.3	4.4	4	3.9	3.8	2.9		225
230		3.6	3.8	4	4.1	4.2	4.3	3.9	3.8	3.7	2.8		230
235			3.5	3.7	3.9	4	4.1	4.2	3.8	3.7	3.6	2.7	235
240				3.6	3.8	3.9	4	4.1	3.7	3.6	3.5	2.6	240
245				3.5	3.7	3.8	3.9	4	3.6	3.5	3.4	2.5	245
250				3.5	3.6	3.7	3.8	3.9	3.5	3.4	3.3	2.4	250
255					3.5	3.6	3.7	3.8	3.4	3.4	3.2	2.4	255
260					3.5	3.6	3.6	3.7	3.3	3.3	3	2.3	260
265					3.4	3.5	3.6	3.6	3.2	3.1	2.7		265
270						3.4	3.5	3.4	3.1	3.1	2.4		270
275						3.4	3.4	3	3	3			275
280						2.7	3.4	2.9	2.9	2.9			280
285							3	2.8	2.9	2.8			285
290							2.6	2.7	2.8	2.6			290
295								2.7	2.7	2.3			295
300								2.5	2.5				300
305									2.3				305

Lifting heights

Hauteurs de levage

TNZF

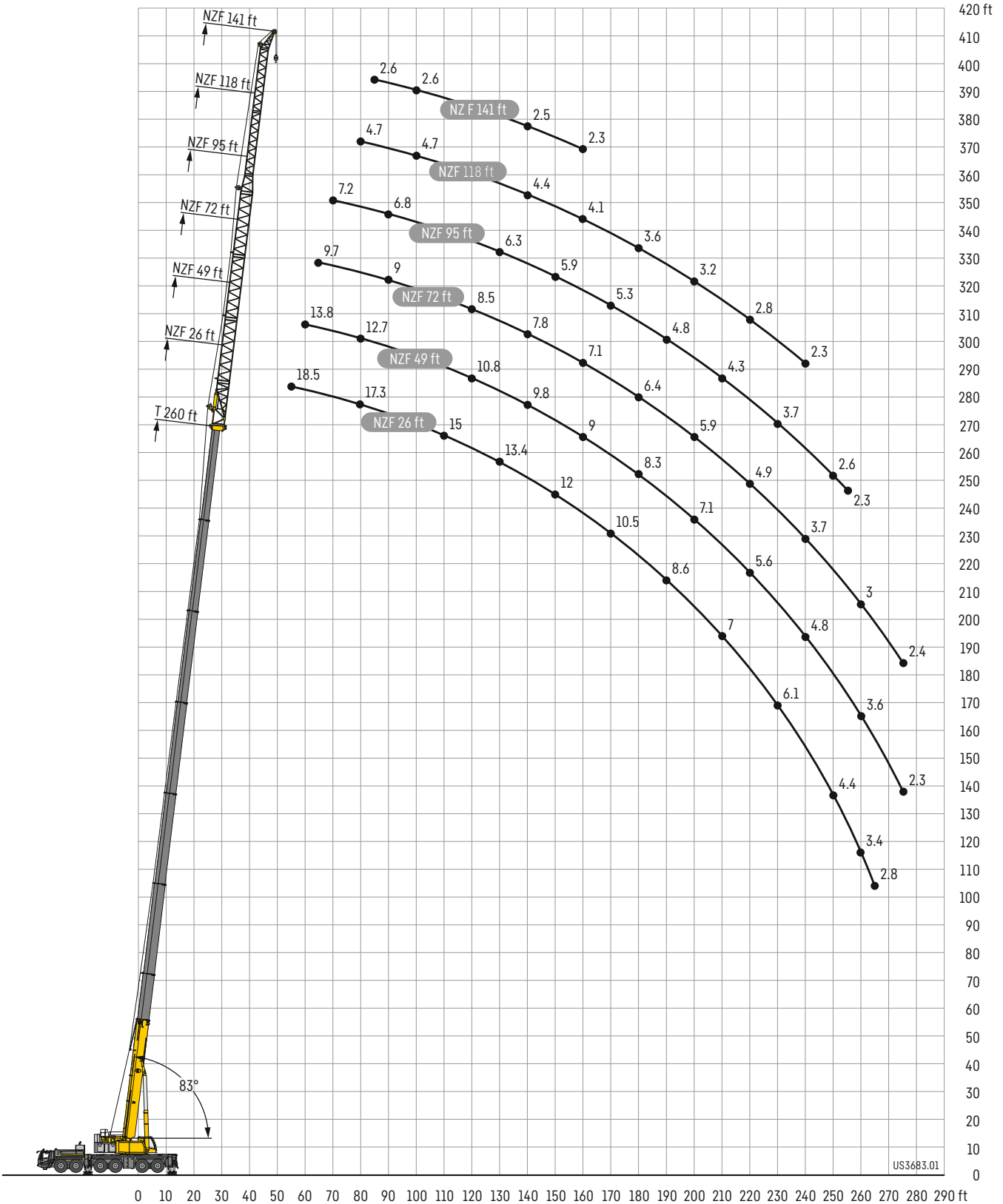

Lifting capacities

Forces de levage

TNZF 26 ft

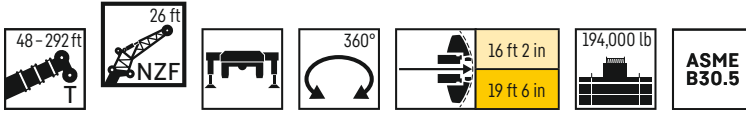

	48 ft			114 ft			130 ft			146 ft			162 ft			179 ft			195 ft			
	NZF 26 ft																					
	0°	22.5°	45°	0°	22.5°	45°	0°	22.5°	45°	0°	22.5°	45°	0°	22.5°	45°	0°	22.5°	45°	0°	22.5°	45°	
11	90.9																					11
12	90.9																					12
13	90.9																					13
14	90.9																					14
15	90.9																					15
16	90.9																					16
17	90.9																					17
18	90																					18
19	88.1																					19
20	85.8	59.9																				20
22	81.5	57.8		88.4																		22
24	77.9	55.8		86.1			84.8															24
26	74.1	53.9		84			82.9															26
28	71	52.3	42.1	81.5			80.9			78.4												28
30	67.9	50.8	41	79.5			79.3			77												30
32	65.3	49.2	40	77.6	53.7		77.5			75.7			64.6									32
34	62.8	47.6	39	75.8	52.9		76	52.8		74.5			63.8									34
36	60.2	46.1	38.2	73.8	51.9		74.4	52.1		73			62.7			57.1						36
38	57.9	44.6	37.5	72.1	51	39.9	72.7	51.3		71.6	51.6		61.5			56.6						38
40	55.4	43.2	36.7	70.4	50.1	39.4	71.2	50.4		70.3	50.8		60.3			56				49.7		40
45	49.8	40.1	35.1	66.3	48	38.2	67.3	48.4	38.5	67.1	49	39.4	57.3	44.4		53.9				48.9		45
50	45	37.5	33.7	62.7	46.1	37.1	63.7	46.7	37.5	64	47.4	38.5	54.6	43	35.1	51.8	42			48	33.5	50
55	41.2	35.3	32.8	59.3	44.4	36.2	60.6	45.2	36.6	61.3	45.8	37.6	52.1	41.6	34.5	49.8	40.7	34.1	47	40.2		55
60	37.9	33.5	32.3	56.2	42.5	35.3	57.8	43.7	35.7	58.7	44.4	36.8	49.8	40.3	33.8	47.8	39.6	33.5	45.9	39.1	33.7	60
65	35.1	32.2	32.3	53.7	40.8	34.4	55.3	42.1	34.9	56.2	43.1	36	47.7	39.1	33.1	46.2	38.5	32.9	44.4	38.1	33.2	65
70	32.8	31.7		51.2	39.2	33.8	53	40.6	34.2	54.1	42	35.2	45.6	37.7	32.5	44.5	37.3	32.4	42.7	37	32.7	70
75				48.9	37.9	33.2	50.9	39.1	33.6	52	40.9	34.6	43.6	36.5	32	42.8	36	31.9	40.4	35.8	32.2	75
80				46.5	36.7	32.7	48.9	38	33.1	50.3	39.7	34	41.6	35.1	31.5	41.2	34.9	31.4	38.3	34.6	31.8	80
85				44.3	35.6	32.3	46.9	36.8	32.6	48.5	38.6	33.5	39.8	34	31	39.6	33.8	30.9	36.2	33.7	31.2	85
90				42.3	34.6	31.9	45	35.8	32.2	46.9	37.5	33.1	38.3	32.9	30.3	38	32.8	30.2	34.3	32.8	30.5	90
95				40.5	33.8	31.7	43.2	34.9	31.9	45.4	36.5	32.7	36.8	31.8	29.6	36.7	31.8	29.6	32.5	31.9	29.9	95
100				38.8	33	31.6	41.6	34.1	31.6	43.8	35.6	32.4	35.3	30.8	29	35.3	31	29	30.8	30.9	29.3	100
105				37.3	32.4	31.6	39.9	33.4	31.5	41.1	34.9	32.2	34.1	29.9	28.4	34	30.1	28.4	29.1	29.7	28.7	105
110				35.9	31.8	31.6	38.5	32.7	31.4	38	34.2	32	32.9	29	27.8	32.7	29.3	27.9	27.6	28.3	28	110
115				34.7	31.4	31.6	36.8	32.1	31.4	35.2	33.5	31.8	31.8	28.3	27.3	31.3	28.6	27.4	26.1	26.9	27.4	115
120				33.6	31.1	31.6	34.4	31.7	31.4	32.6	32.9	31.8	30.7	27.6	26.9	29.9	27.9	26.9	24.7	25.5	26.2	120
125				32.7	31.1	31.6	32.1	31.3	31.4	30.2	31.2	31.4	29.6	26.9	26.5	28.5	27.2	26.5	23.2	23.9	24.6	125
130				29.7	30.8		29.9	30.4	30.6	28.1	28.9	29.2	28.7	26.3	26.1	27.2	26.6	26.2	21.8	22.5	23	130
135				23.6	24		27.9	28.4	28.4	26.5	26.8	27	27.2	25.8	25.7	25.8	25.9	25.8	20.4	21.1	21.5	135
140							26	26.5	26.3	25.8	24.8	25.4	25.3	25.3	25.5	24.2	24.8	25	19.2	19.8	20.2	140
145							23.8	24.1	24.5	25.1	24.1	25.4	23.6	24.2	24.5	22.6	23.4	23.7	18.7	18.5	18.9	145
150							19.8	20.6		23.9	23.8	24.2	22	22.6	22.7	20.9	21.7	22	18.1	17.3	17.7	150
155										22.4	22.7	22.5	20.5	21	21.1	19.4	20.1	20.4	17.6	16.8	16.9	155
160										19.7	20.9		19.1	19.6	19.5	18	18.7	18.9	17.2	16.4	16.7	160
165										15	15.7		17.9	18.2	18.3	16.7	17.3	17.4	16.7	16.1	16.4	165
170										9.5			16.9	17.2	17	15.7	16	16	16.2	15.8	16.2	170
175													14.7	15.3		15.3	15	15.7	15.4	15.4	15.9	175
180													13.4	14.1		14.8	14.8	15.2	14.3	14.8	14.9	180
185													9.4			14.2	14.3	14.5	13.3	13.7	13.7	185
190																12.5	13.3		12.3	12.7	12.6	190
195																10.4	11		11.4	11.7	11.6	195
200																8.3			10.6	10.9	10.7	200
205																			9.6	10	6.2	205
210																			8.9	9.1		210
215																			6.6	6.7		215

Lifting capacities

Forces de levage

TNZF 26 ft

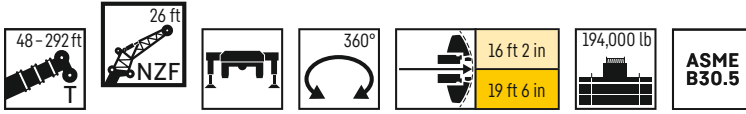

	211 ft			227 ft			243 ft			260 ft			276 ft			292 ft			
	TNZF 26 ft																		
	0°	22.5°	45°	0°	22.5°	45°	0°	22.5°	45°	0°	22.5°	45°	0°	22.5°	45°	0°	22.5°	45°	
45	36.8																		45
50	35.5			31.7			24.1												50
55	34.3	30.9		31			24.1			18.5									55
60	33.3	29.9		30.2	27.6		24.1			18.4			14.7						60
65	32.1	28.8	26.7	29.4	26.7		24	23.1		18.2			14.7			11.3			65
70	31.2	27.7	25.8	28.6	25.8	24.3	23.6	22.5		17.9	17.4		14.4			11.2			70
75	30.1	26.7	25	27.6	25	23.6	23.2	22	21.4	17.6	17.1		14.1	14.1		11.1			75
80	28.9	25.8	24.2	26.7	24.2	23	22.7	21.5	20.9	17.3	16.7	16.4	13.8	13.7		11	11		80
85	27.9	24.9	23.5	25.9	23.5	22.4	22.1	20.9	20.4	16.9	16.3	15.9	13.5	13.4	13.6	10.8	10.8		85
90	26.9	24.1	22.9	25.1	22.8	21.8	21.5	20.4	20	16.6	15.8	15.5	13.2	13	13.2	10.6	10.6	10.8	90
95	26	23.4	22.2	24.3	22.2	21.3	20.9	20	19.5	16.2	15.4	15.1	12.8	12.7	12.8	10.4	10.4	10.6	95
100	25	22.7	21.7	23.6	21.6	20.8	20.2	19.5	19.1	15.8	14.9	14.7	12.4	12.3	12.4	10.2	10.2	10.4	100
105	24.2	22	21.1	22.9	21	20.3	19.5	19.1	18.7	15.4	14.5	14.3	12.1	11.9	12.1	10	10	10.2	105
110	23.4	21.3	20.5	22.2	20.5	19.8	18.9	18.7	18.3	15	14.2	13.9	11.7	11.6	11.7	9.8	9.8	10	110
115	22.7	20.7	20	21.5	20	19.4	18.2	18.1	18	14.6	13.8	13.6	11.4	11.2	11.3	9.6	9.6	9.7	115
120	21.9	20.1	19.5	20.8	19.5	18.9	17.5	17.6	17.5	14.2	13.5	13.3	11.1	11	11.1	9.4	9.4	9.5	120
125	21.2	19.6	19.1	20.1	19	18.5	16.9	17	17.1	13.8	13.1	13	10.8	10.7	10.8	9.2	9.1	9.3	125
130	20.4	19.1	18.7	19.2	18.5	18.2	16.3	16.5	16.7	13.4	12.8	12.7	10.6	10.4	10.5	9	8.9	9.1	130
135	19.6	18.6	18.3	18.1	17.9	17.8	15.7	15.9	16.2	13.1	12.5	12.4	10.3	10.2	10.3	8.8	8.8	8.9	135
140	18.9	18.1	17.9	17.1	17.1	17.2	15.1	15.4	15.6	12.7	12.2	12.1	10.1	9.9	10.1	8.6	8.6	8.7	140
145	18.3	17.4	17.4	16.1	16.4	16.5	14.4	14.8	15	12.4	11.9	11.9	9.8	9.7	9.9	8.4	8.4	8.5	145
150	17.7	17	17	15.1	15.6	15.8	13.8	14.1	14.4	12	11.6	11.6	9.6	9.5	9.6	8.2	8.2	8.3	150
155	17.1	16.6	16.8	14.2	14.8	15.1	13.1	13.5	13.7	11.6	11.4	11.4	9.3	9.3	9.4	8	8	8.1	155
160	16.4	16.2	16.4	13.5	13.8	14.2	12.4	12.8	13.1	11.3	11.1	11.2	9.1	9.1	9.2	7.8	7.8	7.9	160
165	15.8	15.7	16	13	13	13.3	11.7	12.2	12.5	10.9	10.8	10.9	8.9	8.9	9	7.6	7.6	7.7	165
170	15.1	15.2	15.4	12.4	12.5	12.8	11.1	11.5	11.8	10.5	10.6	10.7	8.7	8.7	8.8	7.4	7.5	7.6	170
175	14.4	14.6	14.9	11.9	12	12.2	10.4	10.9	11.1	10	10.3	10.5	8.5	8.5	8.6	7.1	7.3	7.4	175
180	13.7	14	14.2	11.4	11.5	11.7	10	10.2	10.4	9.5	9.9	10.2	8.3	8.3	8.4	6.8	7.1	7.2	180
185	12.8	13.3	13.4	11	11.1	11.3	9.7	9.8	9.9	9.1	9.4	9.7	8	8.1	8.2	6.5	6.8	6.9	185
190	11.8	12.3	12.4	10.7	10.7	10.9	9.4	9.4	9.6	8.6	9	9.2	7.8	7.9	8	6.2	6.5	6.7	190
195	11	11.4	11.4	10.4	10.4	10.6	9.1	9.1	9.3	8.2	8.5	8.7	7.5	7.6	7.7	5.9	6.2	6.4	195
200	10.2	10.5	10.5	10.2	10.2	10.4	8.8	8.8	9	7.7	8	8.2	7.1	7.3	7.5	5.6	5.9	6	200
205	9.4	9.7	9.6	9.9	10	10.2	8.5	8.6	8.7	7.3	7.6	7.7	6.8	7	7.2	5.4	5.6	5.7	205
210	9	9.1	9.1	9.1	9.5	9.5	8.2	8.3	8.4	7	7.1	7.3	6.4	6.7	6.9	5.1	5.3	5.4	210
215	8.6	8.7	8.7	8.4	8.7	8.7	7.9	8	8.2	6.8	6.9	7	6	6.3	6.4	4.8	5	5.1	215
220	8.3	8.4		7.7	8	7.9	7.6	7.8	7.9	6.5	6.6	6.7	5.5	5.8	5.9	4.5	4.7	4.8	220
225	6.8	7.2		7	7.3	7.1	7.1	7.4	7.5	6.3	6.4	6.5	5.1	5.4	5.5	4.2	4.4	4.5	225
230	5.5	5.6		6.7	6.8	6.8	6.6	6.8	6.9	6.1	6.2	6.2	4.7	5	5	3.9	4.1	4.3	230
235				6.4	6.5		6.2	6.4	6.4	5.9	6	6	4.3	4.6	4.6	3.7	3.9	4	235
240				5.4	5.8		5.6	5.8	5.7	5.5	5.7	5.7	3.9	4.2	4.2	3.4	3.6	3.6	240
245				4.4	4.5		5.2	5.3	5.3	4.9	5.2	5.2	3.5	3.8	3.7	3.1	3.3	3.3	245
250							5	5		4.4	4.6	4.5	3	3.3	3.3	2.7	2.9	2.9	250
255							4	4.4		3.9	4.1	3.9	2.5	2.8	2.8	2.4	2.6	2.6	255
260										3.4	3.5			2.2					260
265										2.8	3								265

Lifting capacities

Forces de levage

TNZF 49 ft

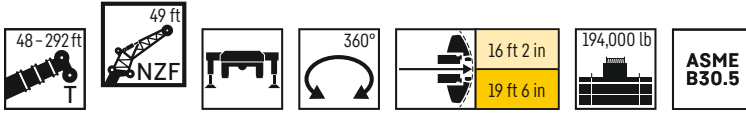

	48 ft			114 ft			130 ft			146 ft			162 ft			179 ft			195 ft				
	TNZF 49 ft																						
	0°	22.5°	45°	0°	22.5°	45°	0°	22.5°	45°	0°	22.5°	45°	0°	22.5°	45°	0°	22.5°	45°	0°	22.5°	45°		
14	73.4																					14	
15	71.3																						15
16	69.2																						16
17	67.2																						17
18	65.2																						18
19	63.3																						19
20	61.9																						20
22	58.7																						22
24	55.7																						24
26	53			56.1																			26
28	50.7			54.6			53.6																28
30	48.5			53.2			52.4			51.2													30
32	46.5			51.8			51.1			50.2													32
34	44.3	32.1		50.4			50			49.2													34
36	42.6	31		49.1			48.7			48.2			42.1										36
38	40.7	29.9		47.9			47.7			47.2			41.5										38
40	39	28.8		46.7			46.5			46.3			40.8			37.7							40
45	35.3	26.5		43.7	29.3		44.1			44.1			39.1			36.4				33.4			45
50	31.7	24.4	20.2	41	27.9		41.7	28.3		42	28.9		37.6			35.1				32.5			50
55	28.7	22.7	19.1	38.5	26.4		39.3	26.9		40.1	27.9		36	25.3		33.9				31.6			55
60	26.2	21.2	18.2	36.2	25.2	19.4	37.3	25.7	19.5	38.1	26.8		34.5	24.4		32.7	24			30.7			60
65	24	19.9	17.4	34.3	24.1	18.8	35.3	24.6	18.9	36.3	25.7	19.6	33.2	23.5		31.7	23.2			29.8	22.8		65
70	22.1	18.8	16.7	32.4	23.1	18.3	33.6	23.6	18.4	34.6	24.8	19.1	31.8	22.7	18	30.5	22.5			28.9	22.2		70
75	20.5	17.7	16.3	30.8	22.1	17.8	32	22.7	18	33	23.9	18.7	30.6	22	17.6	29.6	21.8	17.5		28.1	21.5	17.3	75
80	19	16.9	15.9	29.2	21.3	17.4	30.5	21.9	17.6	31.6	23	18.3	29.3	21.3	17.2	28.6	21.2	17.1		27.3	20.9	17	80
85	17.8	16.2	15.9	27.7	20.5	17	29.1	21.1	17.2	30.3	22.3	17.9	28.1	20.6	16.9	27.6	20.6	16.8		26.6	20.4	16.7	85
90	16.7	15.7		26.3	19.8	16.6	27.8	20.4	16.9	29.1	21.5	17.5	27	20.1	16.6	26.7	20	16.6		25.9	19.8	16.5	90
95	15.8			24.8	19.1	16.4	26.5	19.8	16.6	28	20.9	17.2	25.9	19.5	16.4	25.7	19.4	16.3		25.1	19.4	16.2	95
100				23.6	18.5	16.1	25.3	19.2	16.3	27	20.3	16.9	25	19	16.1	24.8	19	16.1		24.5	18.9	16	100
105				22.6	17.9	15.9	24.1	18.6	16.1	25.9	19.7	16.7	24	18.5	15.9	24	18.5	15.9		23.7	18.5	15.8	105
110				21.5	17.4	15.7	23.1	18.1	15.8	25	19.2	16.5	23	18.1	15.7	23.2	18.1	15.7		23	18	15.6	110
115				20.7	17	15.6	22.2	17.6	15.7	24.1	18.7	16.3	22.1	17.7	15.6	22.4	17.7	15.5		22.2	17.6	15.5	115
120				19.8	16.5	15.5	21.3	17.2	15.5	23.2	18.2	16.1	21.3	17.3	15.4	21.6	17.4	15.4		21.6	17.3	15.3	120
125				19	16.2	15.5	20.5	16.8	15.4	22.3	17.8	16	20.5	16.9	15.3	20.8	17	15.2		20.8	17	15.2	125
130				18.3	15.9	15.5	19.7	16.4	15.4	21.5	17.4	15.8	19.8	16.6	15.2	20.1	16.7	15.1		20.2	16.7	15.1	130
135				17.6	15.6	15.5	19	16.1	15.4	20.8	17	15.7	19.1	16.3	15.1	19.5	16.4	15.1		19.4	16.4	15	135
140				17.1	15.4	15.5	18.4	15.8	15.4	20.1	16.7	15.7	18.5	16	15.1	18.8	16.1	15		18.5	16.2	14.9	140
145				16.5	15.3	15.5	17.7	15.6	15.4	19.4	16.4	15.7	17.9	15.7	15	18.3	15.9	14.9		17.4	15.9	14.8	145
150				16.1	15.3		17.2	15.4	15.4	18.8	16.1	15.7	17.3	15.4	15	17.8	15.6	14.9		16.3	15.6	14.8	150
155				15.7	15.3		16.7	15.2	15.4	18.3	15.9	15.7	16.8	15.1	14.9	17.3	15.3	14.9		15.3	15.2	14.7	155
160				13.5			16.3	15.2	15.4	17.7	15.7	15.7	16.3	14.8	14.9	16.7	15	14.8		14.3	14.7	14.5	160
165							15.9	15.2		17.2	15.5	15.7	15.8	14.5	14.8	16.3	14.7	14.7		13.4	14.2	14.3	165
170							15.2	15.2		16.7	15.4	15.7	15.4	14.3	14.8	15.9	14.5	14.6		12.5	13.5	13.9	170
175							11.7			15.7	15.4	15.7	15	14.1	14.8	15.4	14.3	14.6		11.8	12.6	13.1	175
180										13.9	15.1		14.6	13.9	14.8	14.3	14.1	14.6		11	11.7	12.2	180
185										13.4	13.8		14.2	13.8	14.8	13.2	13.8	14.4		10.5	11.1	11.4	185
190										9.2			13.4	13.7	13.8	12.3	13.1	13.3		10.2	10.4	10.6	190
195													11.9	12.9	11.6	11.4	12.1	12.1		10	9.8	10	195
200													9.5	10.8		10.6	11.1	11.1		9.8	9.5	10	200
205													8.4	4.9		9.8	10.4	10.1		9.6	9.4	10	205
210																9.2	9.5	9.9		9.4	9.3	9.9	210
215																8.6	9.1			9	9.2	9.5	215
220																6.7	7.2			8.3	8.8	8.6	220
225																4.5				7.8	8.1		225
230																				6.7	7.3		230
235																				6.1	6.5		235
240																				4.2			240

Lifting capacities

Forces de levage

TNZF 49 ft

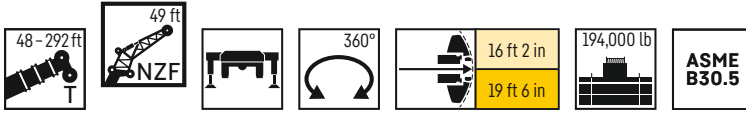

	211 ft			227 ft			243 ft			260 ft			276 ft			292 ft			
	TNZF 49 ft																		
	0°	22.5°	45°	0°	22.5°	45°	0°	22.5°	45°	0°	22.5°	45°	0°	22.5°	45°	0°	22.5°	45°	
50	26.1			19															50
55	25.3			22.1			15.8												55
60	24.6			21.6			17.9			13.8									60
65	23.7			21.1			17.5			13.4			10.5						65
70	23	19.1		20.5			17.2			13.1			10.3			8.2			70
75	22.2	18.5		20	17.3		16.9			12.9			10.2			8.1			75
80	21.3	17.9	15.2	19.4	16.8		16.6	15.4		12.7			10			8			80
85	20.5	17.4	14.8	18.7	16.2	14.3	16.4	15		12.5	12		9.9			7.9			85
90	19.8	16.8	14.5	18.1	15.7	14	16.2	14.6		12.3	11.6		9.8	10		7.8			90
95	19	16.2	14.2	17.5	15.3	13.8	15.9	14.2	13.3	12.2	11.3		9.8	9.9		7.7	7.9		95
100	18.3	15.7	14	17	14.8	13.5	15.4	13.8	13	12	11	10.6	9.7	9.9		7.6	7.8		100
105	17.7	15.2	13.7	16.5	14.4	13.3	15	13.4	12.7	11.6	10.7	10.4	9.6	9.7	9.7	7.6	7.8		105
110	17	14.8	13.5	16	14	13.1	14.6	13.1	12.4	11.3	10.5	10.2	9.5	9.4	9.5	7.5	7.8		110
115	16.4	14.3	13.2	15.4	13.6	12.7	14.2	12.7	12.1	11	10.3	10	9.3	9.2	9.4	7.5	7.8	8.1	115
120	15.9	13.9	13	15	13.2	12.5	13.9	12.4	11.9	10.8	10	9.8	9.1	9	9.2	7.4	7.7	7.9	120
125	15.3	13.4	12.7	14.5	12.8	12.2	13.5	12.1	11.6	10.5	9.8	9.6	8.9	8.8	9	7.4	7.5	7.7	125
130	14.8	13.1	12.4	14.1	12.5	12	13.2	11.9	11.4	10.3	9.6	9.4	8.7	8.6	8.8	7.3	7.3	7.5	130
135	14.3	12.7	12.1	13.7	12.2	11.7	12.8	11.6	11.2	10	9.4	9.2	8.4	8.4	8.5	7.1	7.1	7.3	135
140	13.9	12.4	11.8	13.3	11.9	11.5	12.5	11.3	11	9.8	9.2	9	8.2	8.2	8.3	7	7	7.2	140
145	13.4	12	11.6	12.9	11.6	11.3	12.2	11.1	10.9	9.6	9	8.9	8.1	8	8.1	6.8	6.8	7	145
150	13	11.7	11.4	12.6	11.4	11.1	11.8	10.9	10.7	9.4	8.8	8.7	7.8	7.8	7.9	6.6	6.6	6.8	150
155	12.6	11.4	11.2	12.2	11.1	10.9	11.5	10.7	10.6	9.2	8.7	8.6	7.6	7.6	7.7	6.5	6.5	6.7	155
160	12.3	11.1	11	11.8	10.9	10.7	11.1	10.5	10.4	9	8.5	8.4	7.5	7.4	7.5	6.3	6.3	6.5	160
165	11.9	10.9	10.8	11.4	10.7	10.6	10.7	10.3	10.3	8.8	8.3	8.3	7.3	7.2	7.4	6.2	6.2	6.4	165
170	11.5	10.7	10.7	11	10.5	10.5	10.3	10.1	10.2	8.6	8.2	8.1	7.1	7	7.2	6	6	6.2	170
175	11.1	10.5	10.5	10.5	10.3	10.3	9.9	10	10	8.4	8	8	6.9	6.9	7	5.8	5.9	6.1	175
180	10.8	10.3	10.4	10.1	10.1	10.2	9.5	9.8	9.9	8.3	7.9	7.9	6.7	6.7	6.9	5.6	5.7	5.9	180
185	10.5	10.2	10.3	9.6	9.9	10	9	9.6	9.8	8	7.8	7.8	6.6	6.5	6.7	5.4	5.6	5.7	185
190	10.3	10	10.2	9.3	9.7	9.8	8.5	9.2	9.5	7.8	7.6	7.7	6.4	6.4	6.5	5.2	5.4	5.6	190
195	10.1	9.7	10.1	9	9.2	9.6	8	8.7	9.1	7.5	7.5	7.6	6.2	6.2	6.4	4.9	5.3	5.5	195
200	9.9	9.6	9.9	8.7	8.9	9.2	7.6	8.2	8.6	7.1	7.3	7.5	6.1	6.1	6.3	4.6	5.1	5.3	200
205	9.7	9.5	9.9	8.4	8.6	8.8	7.4	7.8	8.1	6.8	7	7.3	5.8	6	6.1	4.4	4.8	5.2	205
210	9.4	9.4	9.8	8.2	8.3	8.5	7.1	7.3	7.6	6.4	6.7	7	5.5	5.8	6	4.1	4.6	4.9	210
215	8.7	9.2	9.6	7.9	8.1	8.3	6.9	7	7.1	6	6.5	6.7	5.2	5.6	5.8	3.9	4.3	4.6	215
220	7.9	8.7	8.7	7.6	7.8	8	6.7	6.8	7	5.6	6.2	6.4	5	5.3	5.6	3.6	4.1	4.3	220
225	7.2	7.9	7.8	7.1	7.6	7.8	6.5	6.6	6.8	5.4	5.7	6	4.6	5.1	5.3	3.4	3.8	4.1	225
230	6.8	7.1	7.3	6.9	7.1	7.3	6.3	6.4	6.6	5.2	5.3	5.5	4.3	4.8	5.1	3.2	3.5	3.8	230
235	6.7	6.7	6.4	6.4	6.8	7	6	6.2	6.4	5	5.1	5.3	3.9	4.5	4.8	2.9	3.3	3.5	235
240	6.5	6.6		5.8	6.3	6.3	5.6	6	6.1	4.8	5	5.1	3.6	4.1	4.3	2.7	3.1	3.2	240
245	5.8	6.2		5.3	5.7	5.6	5.1	5.7	5.8	4.6	4.8	4.9	3.2	3.7	3.9	2.4	2.8	3	245
250	4.6	4.9		5.1	5.2	5.1	4.7	5.1	5.1	4.5	4.6	4.8	2.9	3.4	3.5		2.5	2.7	250
255	2.7			4.8	5		4.3	4.7	4.7	4.1	4.4	4.5	2.5	3	3		2.3	2.4	255
260				4.2	4.6		3.9	4.2	4.1	3.6	4.1	4.2		2.6	2.6				260
265				3.4	3.4		3.6	3.8		3.2	3.7	3.7		2.2	2.3				265
270							3.4	3.5		2.7	3.2	3.1							270
275							2.7	3.1		2.3	2.7	2.5							275

Lifting capacities

Forces de levage

TNZF 72 ft

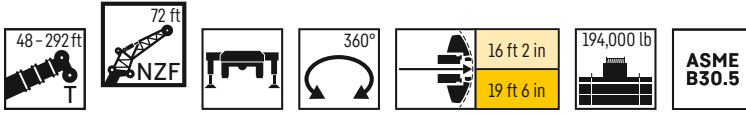

	48 ft			114 ft			130 ft			146 ft			162 ft			179 ft			195 ft			
	TNZF 72 ft																					
	0°	22.5°	45°	0°	22.5°	45°	0°	22.5°	45°	0°	22.5°	45°	0°	22.5°	45°	0°	22.5°	45°	0°	22.5°	45°	
18	51.3																					18
19	50																					19
20	48.7																					20
22	46.6																					22
24	44.4																					24
26	42.5																					26
28	40.6			40.2																		28
30	38.9			39.2																		30
32	37.2			38.3			37.6															32
34	35.6			37.4			36.7			35.5												34
36	34.1			36.5			35.9			34.9												36
38	32.8			35.5			35.2			34.2			29.9									38
40	31.5			34.6			34.4			33.4			29.4									40
45	28.3	21		32.7			32.5			31.9			28.2			26.2						45
50	25.8	19.3		30.6			30.8			30.4			27			25.4			23.4			50
55	23.5	17.7		28.7			29.2			28.9			25.9			24.5			22.7			55
60	21.3	16.4		27	18.2		27.5	18.4		27.5			24.7			23.7			22			60
65	19.4	15.3	12.6	25.4	17.3		26	17.5		26.1	17.6		23.6			22.8			21.4			65
70	17.8	14.2	11.8	23.9	16.4		24.6	16.7		24.9	16.8		22.7	15.4		22			20.7			70
75	16.3	13.3	11.2	22.7	15.6		23.3	15.9		23.7	16.1		21.7	14.8		21.2	15.3		20.1	15.1		75
80	15	12.5	10.7	21.5	15	11.3	22.2	15.3	11.4	22.6	15.5		20.8	14.3		20.5	14.8		19.5	14.6		80
85	13.9	11.7	10.4	20.3	14.3	11	21.1	14.7	11.1	21.6	14.9	11.1	20	13.8		19.8	14.3		18.9	14.1		85
90	12.9	11.1	10	19.3	13.7	10.8	20.1	14.1	10.9	20.6	14.3	10.9	19.1	13.3	10.4	19.2	13.8	10.8	18.3	13.7		90
95	12	10.6	9.8	18.2	13.1	10.5	19.2	13.5	10.6	19.7	13.8	10.7	18.3	12.9	10.2	18.5	13.4	10.6	17.8	13.3	10.6	95
100	11.3	10.2	9.5	17.3	12.6	10.3	18.3	13	10.4	18.9	13.4	10.5	17.6	12.5	10.1	17.8	13	10.5	17.3	12.9	10.4	100
105	10.6	9.8	9.5	16.4	12.2	10.1	17.4	12.6	10.2	18.1	12.9	10.3	16.9	12.1	9.9	17.3	12.7	10.3	16.8	12.6	10.3	105
110	10.1	9.5	9.5	15.5	11.7	9.9	16.7	12.1	10.1	17.4	12.5	10.1	16.2	11.8	9.8	16.7	12.3	10.2	16.3	12.2	10.1	110
115	9.6	9.3		14.8	11.3	9.8	15.8	11.7	9.9	16.7	12.1	10	15.6	11.4	9.6	16.1	12	10	15.8	11.9	10	115
120				14.1	11	9.6	15.1	11.3	9.7	16	11.7	9.8	15	11.1	9.5	15.6	11.7	9.9	15.4	11.6	9.9	120
125				13.4	10.7	9.5	14.4	11	9.6	15.3	11.4	9.7	14.4	10.8	9.4	15.1	11.4	9.8	14.9	11.3	9.7	125
130				12.8	10.4	9.4	13.8	10.7	9.5	14.6	11	9.6	13.9	10.6	9.3	14.6	11.1	9.7	14.5	11.1	9.7	130
135				12.2	10.1	9.3	13.2	10.5	9.4	14.1	10.8	9.5	13.4	10.4	9.2	14.1	10.9	9.6	14.1	10.8	9.6	135
140				11.7	9.9	9.3	12.7	10.2	9.3	13.5	10.5	9.4	12.9	10.2	9.1	13.6	10.7	9.5	13.7	10.7	9.5	140
145				11.3	9.7	9.3	12.2	10	9.3	13	10.3	9.3	12.5	10	9.1	13.2	10.5	9.4	13.2	10.5	9.4	145
150				10.9	9.6	9.3	11.7	9.9	9.2	12.5	10.1	9.2	12.1	9.9	9	12.8	10.3	9.3	12.9	10.3	9.3	150
155				10.5	9.4	9.3	11.3	9.7	9.2	12	9.9	9.2	11.7	9.7	9	12.5	10.1	9.3	12.5	10.2	9.3	155
160				10.2	9.3	9.3	10.9	9.5	9.2	11.6	9.7	9.2	11.3	9.5	8.9	12.1	10	9.2	12.2	10	9.2	160
165				9.9	9.2	9.3	10.6	9.4	9.2	11.2	9.6	9.2	11	9.4	8.9	11.8	9.8	9.2	11.9	9.9	9.2	165
170				9.7	9.2		10.3	9.3	9.2	10.9	9.5	9.1	10.8	9.3	8.9	11.4	9.7	9.2	11.5	9.7	9.1	170
175				9.5	9.2		10	9.2	9.2	10.6	9.3	9.1	10.5	9.2	8.9	11.1	9.6	9.2	11.1	9.6	9.1	175
180				9.3			9.8	9.1	9.2	10.4	9.2	9.1	10.3	9.1	8.9	10.9	9.5	9.2	10.7	9.5	9.1	180
185							9.6	9.1		10.1	9.1	9.1	10.1	9	8.9	10.6	9.4	9.2	10.2	9.4	9.1	185
190							9.4	9.1		9.9	9.1	9.1	9.9	8.9	8.9	10.4	9.3	9.2	9.8	9.3	9.1	190
195							9.3	9.1		9.7	9.1	9.1	9.7	8.9	8.9	10.2	9.2	9.2	9.3	9.2	9.1	195
200										9.4	9.1		9.5	8.8	8.9	10	9.1	9.2	8.8	9.1	9.1	200
205										9	9.1		9.3	8.8	8.9	9.8	9	9.2	8.4	8.9	9.1	205
210										8.7	8.9		9.1	8.8	8.9	9.6	9	9.2	7.9	8.5	8.8	210
215										6			8.9	8.8		9.2	9	9.2	7.4	8	8.3	215
220													8.1	8.8		8.4	9	9.1	6.8	7.6	7.7	220
225													6.3	7.3		7.7	8.5	8.3	6.7	7	7.2	225
230													5.5			7	7.7		6.6	6.4	6.9	230
235																6.3	6.9		6.4	6.3	6.9	235
240																5.9	6.3		6.3	6.3	6.8	240
245																4.4			6.1	6.3		245
250																			5.3	6.1		250
255																			4.5	4.8		255
260																			3.2			260

Lifting capacities

Forces de levage

TNZF 72 ft

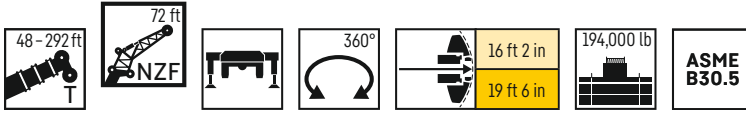

	211 ft			227 ft			243 ft			260 ft			276 ft			292 ft			
	TNZF 72 ft																		
	0°	22.5°	45°	0°	22.5°	45°	0°	22.5°	45°	0°	22.5°	45°	0°	22.5°	45°	0°	22.5°	45°	
50	19.1																		50
55	18.8			16.1															55
60	18.4			15.8			12.8												60
65	18			15.5			12.5			9.7									65
70	17.5			15.2			12.2			9.5			7.7						70
75	17			14.9			12			9.3			7.5			5.5			75
80	16.4	12.5		14.6			11.8			9.2			7.4			5.5			80
85	15.8	12.1		14.2			11.7			9.1			7.3			5.5			85
90	15.2	11.6		13.8	11.1		11.5			9			7.2			5.5			90
95	14.6	11.3		13.3	10.8		11.4	10.3		8.9			7.1			5.5			95
100	14	11	9.3	12.8	10.6		11.2	10.1		8.9	8.7		7.1			5.5			100
105	13.5	10.7	9.2	12.4	10.3	9	11.1	9.9		8.8	8.4		7	7.1		5.4			105
110	13	10.5	9	12	10.1	8.8	10.9	9.7		8.7	8.2		6.9	7.1		5.4			110
115	12.5	10.2	8.9	11.6	9.9	8.7	10.7	9.5	8.5	8.6	8		6.9	7.1		5.3	5.5		115
120	12	10	8.8	11.3	9.7	8.6	10.5	9.3	8.4	8.5	7.8	7.5	6.9	7		5.3	5.5		120
125	11.6	9.8	8.6	10.9	9.5	8.4	10.2	9.1	8.3	8.3	7.7	7.4	6.8	7		5.3	5.5		125
130	11.2	9.6	8.5	10.6	9.3	8.3	10	8.9	8.2	8.2	7.5	7.2	6.8	7	6.8	5.2	5.5		130
135	10.8	9.4	8.4	10.3	9.1	8.2	9.8	8.7	8.1	8	7.3	7	6.7	6.8	6.6	5.2	5.5		135
140	10.5	9.2	8.3	10	8.9	8.1	9.5	8.6	8	7.8	7.2	6.9	6.6	6.7	6.5	5.1	5.5	5.8	140
145	10.2	9	8.2	9.8	8.7	8	9.3	8.4	7.9	7.6	7	6.7	6.5	6.5	6.4	5.1	5.5	5.7	145
150	9.9	8.8	8.1	9.5	8.5	8	9.1	8.2	7.8	7.5	6.8	6.6	6.4	6.3	6.3	5.1	5.3	5.6	150
155	9.7	8.6	8	9.3	8.3	7.9	8.9	8	7.7	7.3	6.7	6.5	6.2	6.2	6.2	5	5.2	5.5	155
160	9.4	8.4	7.9	9.1	8.2	7.8	8.7	7.9	7.6	7.1	6.5	6.4	6	6	6.1	4.9	5.1	5.3	160
165	9.1	8.2	7.9	8.9	8	7.7	8.5	7.7	7.6	6.9	6.4	6.3	5.9	5.9	6	4.8	4.9	5.2	165
170	8.9	8.1	7.8	8.7	7.8	7.6	8.3	7.6	7.5	6.7	6.3	6.1	5.7	5.7	5.8	4.6	4.8	5	170
175	8.7	7.9	7.6	8.5	7.7	7.5	8.2	7.5	7.4	6.6	6.1	6	5.6	5.6	5.7	4.5	4.6	4.9	175
180	8.5	7.7	7.5	8.3	7.6	7.4	8	7.4	7.3	6.4	6	5.9	5.4	5.4	5.6	4.3	4.5	4.8	180
185	8.2	7.6	7.4	8.1	7.4	7.3	7.8	7.2	7.2	6.3	5.9	5.8	5.3	5.3	5.4	4.2	4.4	4.6	185
190	8	7.4	7.3	7.9	7.3	7.2	7.6	7.1	7.1	6.2	5.8	5.7	5.1	5.1	5.3	4	4.2	4.5	190
195	7.8	7.3	7.2	7.7	7.1	7.1	7.3	7	7	6	5.7	5.6	5	5	5.2	3.8	4.1	4.4	195
200	7.7	7.1	7.1	7.5	7	7.1	6.9	6.9	6.9	5.9	5.6	5.6	4.9	4.8	5	3.6	3.9	4.2	200
205	7.5	7	7.1	7.2	6.9	7	6.5	6.8	6.8	5.7	5.4	5.5	4.7	4.7	4.9	3.4	3.8	4.1	205
210	7.2	6.9	7	7	6.8	6.9	6.1	6.6	6.8	5.5	5.3	5.4	4.6	4.6	4.8	3.2	3.6	4	210
215	7	6.7	6.9	6.8	6.6	6.8	5.8	6.3	6.6	5.2	5.2	5.3	4.5	4.5	4.7	3	3.5	3.8	215
220	6.9	6.6	6.9	6.6	6.5	6.7	5.4	6.1	6.4	4.9	5.1	5.3	4.2	4.3	4.5	2.8	3.3	3.7	220
225	6.8	6.5	6.8	6.4	6.4	6.7	5.3	5.8	6.1	4.6	4.9	5.2	4	4.2	4.4	2.5	3.1	3.5	225
230	6.6	6.4	6.8	6.2	6.3	6.6	5.2	5.4	5.8	4.3	4.7	5	3.7	4.1	4.3	2.3	2.9	3.3	230
235	6.4	6.3	6.8	6	6.2	6.5	5.1	5	5.4	4	4.5	4.8	3.4	3.9	4.2		2.7	3.1	235
240	5.8	6.3	6.7	5.6	6	6.2	4.9	4.8	5	3.7	4.3	4.6	3.1	3.7	4		2.4	2.8	240
245	5.3	6.1	6.1	5	5.8	6	4.8	4.7	5	3.6	4	4.4	2.8	3.4	3.8			2.5	245
250	5	5.5	5.3	4.8	5.4	5.6	4.5	4.7	4.9	3.4	3.6	3.9	2.5	3.2	3.5			2.3	250
255	4.8	5	5.1	4.5	4.8	5	4.2	4.5	4.8	3.2	3.5	3.7		2.9	3.2				255
260	4.5	4.7		4	4.6	4.7	3.8	4.4	4.6	3	3.3	3.5		2.6	2.8				260
265	4.4	4.6		3.8	4.2	4	3.3	4.1	4.3	2.9	3.2	3.3		2.2	2.4				265
270	3.3	4.2		3.5	3.8		3.1	3.6	3.6	2.6	3	3.1							270
275				3.3	3.5		2.6	3.2	3.2	2.4	2.8	2.9							275
280				2.7	3.1			2.8	2.6		2.6	2.7							280
285					2.5			2.3			2.2	2.3							285

Lifting capacities

Forces de levage

TNZF 95 ft

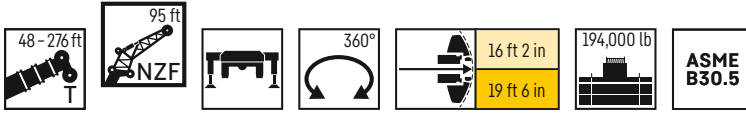

	48 ft			114 ft			130 ft			146 ft			162 ft			179 ft			195 ft			
	TNZF 95 ft																					
	0°	22.5°	45°	0°	22.5°	45°	0°	22.5°	45°	0°	22.5°	45°	0°	22.5°	45°	0°	22.5°	45°	0°	22.5°	45°	
22	36.7																					22
24	35.3																					24
26	34																					26
28	32.7																					28
30	31.5																					30
32	30.3			29.1																		32
34	29.1			28.4																		34
36	28			27.8			27.3															36
38	26.9			27.1			26.7			26.4												38
40	25.8			26.5			26.2			25.9												40
45	23.4			25			24.8			24.7			21.3			19.6						45
50	21.3			23.6			23.6			23.7			20.5			19			17.4			50
55	19.4			22.1			22.3			22.6			19.7			18.3			16.9			55
60	17.7	13.4		20.8			21			21.5			18.8			17.6			16.4			60
65	16.2	12.3		19.5			19.9			20.4			18.1			17			15.9			65
70	14.8	11.4		18.4	12.2		18.7			19.5			17.3			16.4			15.4			70
75	13.5	10.7		17.4	11.6		17.8	11.7		18.5	12.6		16.6			15.8			14.9			75
80	12.4	10.1		16.4	11.1		16.9	11.2		17.6	12.1		15.9	10.9		15.2			14.4			80
85	11.4	9.5	8.2	15.5	10.6		15.9	10.7		16.8	11.6		15.2	10.6		14.6	10.4		14			85
90	10.7	9	7.8	14.7	10.2		15.1	10.3		16	11.1		14.7	10.3		14.1	10.1		13.5	10		90
95	10	8.6	7.5	13.9	9.8	7.8	14.4	10		15.3	10.7		14.1	9.9		13.6	9.8		13	9.7		95
100	9.4	8.2	7.3	13.1	9.5	7.6	13.7	9.6	7.7	14.6	10.3	8.1	13.5	9.6		13.1	9.6		12.6	9.5		100
105	8.9	7.8	7	12.4	9.1	7.5	13	9.3	7.5	13.9	10	7.9	13	9.4	7.5	12.7	9.3		12.2	9.2		105
110	8.4	7.5	6.8	11.8	8.8	7.3	12.3	9	7.3	13.3	9.7	7.7	12.5	9.1	7.4	12.2	9	7.3	11.8	9		110
115	8	7.2	6.6	11.2	8.5	7.1	11.7	8.7	7.2	12.8	9.4	7.5	11.9	8.9	7.2	11.8	8.8	7.2	11.5	8.8	7.2	115
120	7.5	6.9	6.4	10.6	8.3	7	11.1	8.5	7	12.3	9.1	7.4	11.5	8.7	7.1	11.4	8.6	7.1	11.1	8.6	7	120
125	7.2	6.6	6.3	10.1	8	6.8	10.7	8.2	6.9	11.8	8.9	7.3	11.1	8.4	7	11.1	8.4	7	10.8	8.4	6.9	125
130	6.9	6.4	6.3	9.7	7.8	6.7	10.3	8	6.8	11.3	8.6	7.1	10.7	8.2	6.9	10.7	8.2	6.9	10.5	8.2	6.8	130
135	6.6	6.3		9.4	7.5	6.6	9.8	7.8	6.7	10.9	8.4	7	10.4	8	6.8	10.4	8	6.8	10.3	8	6.7	135
140	6.3			9	7.3	6.5	9.5	7.6	6.6	10.5	8.2	6.9	10	7.8	6.7	10.1	7.9	6.7	10	7.9	6.6	140
145				8.7	7.1	6.5	9.1	7.4	6.5	10.1	8	6.8	9.7	7.7	6.6	9.8	7.7	6.6	9.8	7.7	6.5	145
150				8.3	7	6.4	8.8	7.2	6.4	9.8	7.8	6.7	9.4	7.5	6.5	9.5	7.6	6.5	9.5	7.5	6.5	150
155				8	6.8	6.3	8.5	7	6.4	9.5	7.6	6.6	9.2	7.3	6.4	9.3	7.4	6.4	9.3	7.4	6.4	155
160				7.8	6.7	6.3	8.2	6.9	6.3	9.2	7.4	6.5	8.9	7.2	6.3	9	7.3	6.3	9	7.3	6.3	160
165				7.5	6.6	6.3	7.9	6.7	6.3	8.9	7.2	6.5	8.6	7	6.3	8.8	7.1	6.3	8.8	7.1	6.3	165
170				7.3	6.4	6.2	7.7	6.6	6.2	8.6	7.1	6.4	8.4	6.9	6.2	8.5	7	6.2	8.6	7	6.2	170
175				7.1	6.3	6.2	7.5	6.5	6.2	8.3	6.9	6.4	8.2	6.8	6.2	8.3	6.8	6.2	8.4	6.9	6.2	175
180				6.9	6.3	6.2	7.3	6.4	6.2	8.1	6.8	6.3	8	6.7	6.2	8.1	6.7	6.2	8.2	6.8	6.1	180
185				6.7	6.2	6.2	7.1	6.3	6.2	7.8	6.7	6.3	7.8	6.6	6.1	7.9	6.6	6.1	8	6.7	6.1	185
190				6.6	6.2		6.9	6.2	6.2	7.6	6.6	6.3	7.6	6.5	6.1	7.7	6.5	6.1	7.8	6.6	6.1	190
195				6.4	6.2		6.8	6.2	6.2	7.4	6.5	6.3	7.4	6.4	6.1	7.6	6.4	6.1	7.6	6.5	6	195
200				6.3	6.2		6.6	6.1	6.2	7.2	6.4	6.3	7.2	6.3	6.1	7.4	6.3	6.1	7.5	6.4	6	200
205				6.2			6.5	6.1		7	6.3	6.3	7.1	6.2	6.1	7.2	6.3	6.1	7.3	6.3	6	205
210							6.3	6.1		6.8	6.2	6.3	6.9	6.2	6.1	7.1	6.2	6.1	7.1	6.2	6	210
215							6.2	6.1		6.6	6.2	6.3	6.7	6.1	6.1	6.9	6.1	6.1	6.9	6.1	6	215
220							6.2			6.5	6.2		6.6	6.1	6.1	6.8	6.1	6.1	6.8	6.1	6	220
225										6.4	6.2		6.5	6	6.1	6.6	6	6.1	6.5	6	6	225
230										6.2	6.2		6.4	6	6.1	6.5	6	6.1	6	6	6	230
235										5.3			6.3	6		6.4	6	6.1	5.4	6	6	235
240													6.2	6		6.3	6	6.1	4.8	5.9	6	240
245													5.4	6		5.9	6	6.1	4.6	5.6	5.8	245
250													4.3			5.4	6		4.6	4.9	5.1	250
255																4.5	5.5		4.5	4.4	4.9	255
260																4.2	4.7		4.4	4.3	4.9	260
265																			4.2	4.3		265
270																			3.9	4.3		270
275																			3.2	4.2		275
280																				2.7		280

Lifting capacities

Forces de levage

TNZF 95 ft

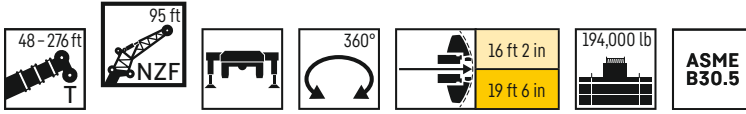

	211 ft			227 ft			243 ft			260 ft			276 ft			
	TNZF 95 ft															
	0°	22.5°	45°	0°	22.5°	45°	0°	22.5°	45°	0°	22.5°	45°	0°	22.5°	45°	
55	13.8															55
60	13.5			11.5												60
65	13.2			11.3			9.4									65
70	12.8			11.1			9.3			7.2						70
75	12.5			11			9.1			7.1			5.2			75
80	12.2			10.8			9			6.9			5.2			80
85	11.9			10.6			8.8			6.9			5.2			85
90	11.6			10.4			8.7			6.8			5.2			90
95	11.2	8.7		10.2			8.6			6.7			5.2			95
100	10.9	8.4		10			8.5			6.6			5.2			100
105	10.6	8.2		9.8	7.9		8.5			6.5			5.1			105
110	10.3	8		9.5	7.7		8.4	7.4		6.5			5.1			110
115	9.9	7.8		9.3	7.5		8.3	7.2		6.4			5			115
120	9.6	7.6	6.4	9	7.4		8.2	7.1		6.4	6.3		5			120
125	9.3	7.4	6.3	8.8	7.2		8	6.9		6.3	6.1		4.9	5.1		125
130	9	7.2	6.2	8.5	7	6	7.9	6.8		6.3	5.9		4.9	5.1		130
135	8.7	7.1	6.1	8.3	6.9	5.9	7.7	6.6	5.8	6.2	5.8		4.8	5.1		135
140	8.5	6.9	6	8	6.7	5.8	7.6	6.5	5.7	6.2	5.6		4.8	5		140
145	8.2	6.8	5.9	7.8	6.6	5.7	7.4	6.4	5.6	6.1	5.5	5.3	4.8	5		145
150	8	6.6	5.8	7.6	6.4	5.7	7.2	6.2	5.6	5.9	5.4	5.2	4.8	5		150
155	7.7	6.5	5.7	7.4	6.3	5.6	7	6.1	5.5	5.8	5.2	5	4.7	4.9	4.7	155
160	7.5	6.3	5.6	7.2	6.2	5.5	6.9	6	5.4	5.6	5.1	4.9	4.6	4.8	4.6	160
165	7.3	6.2	5.5	7	6.1	5.5	6.7	5.9	5.4	5.5	5	4.8	4.5	4.7	4.5	165
170	7.1	6.1	5.5	6.9	6	5.4	6.5	5.8	5.3	5.3	4.9	4.7	4.3	4.6	4.5	170
175	6.9	6	5.4	6.7	5.9	5.3	6.4	5.7	5.3	5.2	4.7	4.6	4.2	4.4	4.4	175
180	6.7	5.8	5.3	6.5	5.7	5.3	6.2	5.6	5.2	5.1	4.6	4.5	4.1	4.3	4.3	180
185	6.5	5.7	5.3	6.3	5.6	5.2	6.1	5.5	5.1	4.9	4.5	4.4	3.9	4.1	4.2	185
190	6.3	5.6	5.3	6.2	5.5	5.2	6	5.4	5.1	4.8	4.4	4.3	3.8	4	4.1	190
195	6.1	5.5	5.2	6	5.4	5.2	5.9	5.3	5.1	4.7	4.3	4.2	3.7	3.9	4.1	195
200	6	5.4	5.2	5.9	5.3	5.1	5.7	5.2	5	4.6	4.2	4.2	3.5	3.7	4	200
205	5.8	5.3	5.1	5.7	5.2	5.1	5.6	5.1	5	4.5	4.1	4.1	3.4	3.6	3.9	205
210	5.7	5.2	5.1	5.6	5.1	5	5.4	5	4.9	4.3	4	4	3.3	3.5	3.8	210
215	5.5	5.1	5	5.5	5	5	5.1	4.9	4.9	4.2	4	3.9	3.1	3.3	3.7	215
220	5.4	4.9	5	5.3	4.9	4.9	4.8	4.8	4.8	4.1	3.9	3.9	3	3.2	3.6	220
225	5.3	4.9	4.9	5.1	4.8	4.9	4.5	4.7	4.8	3.9	3.8	3.8	2.9	3.1	3.4	225
230	5.1	4.8	4.9	5	4.7	4.8	4.2	4.6	4.7	3.7	3.7	3.7	2.8	3	3.3	230
235	5	4.7	4.8	4.9	4.6	4.8	3.9	4.4	4.7	3.4	3.6	3.7	2.6	2.9	3.2	235
240	4.9	4.6	4.8	4.8	4.5	4.7	3.7	4.3	4.5	3.2	3.5	3.6	2.5	2.8	3.1	240
245	4.7	4.5	4.8	4.6	4.4	4.7	3.6	4.1	4.4	2.9	3.4	3.6	2.2	2.6	3	245
250	4.6	4.4	4.7	4.5	4.4	4.6	3.5	3.8	4.2	2.6	3.2	3.5		2.5	2.9	250
255	4.4	4.3	4.7	4.3	4.3	4.6	3.4	3.5	3.9	2.3	3	3.3		2.4	2.7	255
260	4.1	4.3	4.7	3.8	4.3	4.6	3.3	3.2	3.5		2.8	3.1		2.2	2.6	260
265	3.8	4.3	4.7	3.3	4.2	4.5	3.1	3.2	3.4		2.6	2.9			2.4	265
270	3.5	4	4	3.2	4	4.3	2.9	3.1	3.4		2.3	2.6				270
275	3.3	3.6	3.5	2.9	3.5	3.7	2.6	3	3.3			2.3				275
280	3	3.3	3.5	2.5	3	3.3		2.9	3.1							280
285	2.8	3		2.3	2.8	2.4		2.7	3							285
290		3			2.4			2.3	2.5							290

Lifting capacities

Forces de levage

TNZF 118 ft

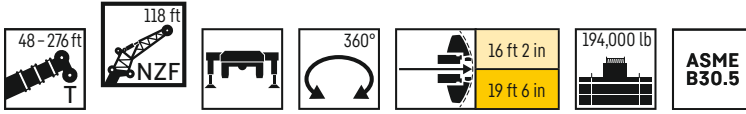

	48 ft			114 ft			130 ft			146 ft			162 ft			179 ft			195 ft			
	TNZF 118 ft																					
	0°	22.5°	45°	0°	22.5°	45°	0°	22.5°	45°	0°	22.5°	45°	0°	22.5°	45°	0°	22.5°	45°	0°	22.5°	45°	
26	26.7																					26
28	26.2																					28
30	25.6																					30
32	24.8																					32
34	24.1																					34
36	23.3			21.7																		36
38	22.4			21.3			20.8															38
40	21.6			20.9			20.5															40
45	19.8			19.8			19.5			18.8			15.7									45
50	18.2			18.7			18.6			18			15.2			14						50
55	16.7			17.6			17.6			17.2			14.7			13.6			12.4			55
60	15.3			16.6			16.7			16.4			14.1			13.1			12.1			60
65	14.1			15.7			15.8			15.6			13.5			12.6			11.7			65
70	12.9	10.2		14.8			14.9			14.9			12.9			12.1			11.3			70
75	12	9.6		13.9			14.1			14.1			12.4			11.7			11			75
80	11.1	9		13.2			13.4			13.4			11.9			11.3			10.7			80
85	10.3	8.5		12.4	9		12.7	9		12.8			11.4			10.9			10.4			85
90	9.6	8		11.7	8.6		12.1	8.7		12.2	8.7		11			10.6			10.1			90
95	9	7.6		11.2	8.3		11.4	8.4		11.6	8.4		10.6	7.8		10.2			9.8			95
100	8.4	7.2		10.7	7.9		11	8		11.1	8.1		10.3	7.5		9.9	7.4		9.6			100
105	7.9	6.8	5.9	10.2	7.6		10.5	7.7		10.6	7.8		9.9	7.3		9.6	7.2		9.3	7.1		105
110	7.5	6.4	5.6	9.8	7.3		10.1	7.5		10.3	7.6		9.6	7.1		9.4	7		9	6.9		110
115	7	6.1	5.4	9.4	7.1	5.6	9.7	7.2		9.9	7.3		9.3	6.8		9.1	6.8		8.8	6.7		115
120	6.6	5.8	5.2	8.9	6.8	5.4	9.3	7	5.4	9.5	7.1	5.5	9	6.6		8.8	6.6		8.6	6.5		120
125	6.3	5.5	5	8.6	6.6	5.3	8.9	6.7	5.3	9.1	6.8	5.3	8.7	6.4	5.1	8.5	6.4		8.3	6.4		125
130	5.9	5.3	4.8	8.2	6.3	5.1	8.6	6.5	5.2	8.8	6.6	5.2	8.4	6.2	5	8.3	6.2	4.9	8.1	6.2		130
135	5.6	5.1	4.6	7.8	6.1	5	8.2	6.3	5	8.5	6.4	5.1	8.1	6.1	4.9	8	6.1	4.8	7.9	6	4.8	135
140	5.3	4.8	4.5	7.5	5.9	4.9	7.9	6.1	4.9	8.1	6.2	5	7.9	5.9	4.8	7.8	5.9	4.7	7.6	5.9	4.7	140
145	5.1	4.6	4.3	7.2	5.7	4.8	7.6	5.9	4.8	7.8	6	4.9	7.6	5.8	4.7	7.6	5.8	4.6	7.4	5.7	4.6	145
150	4.8	4.5	4.3	6.9	5.5	4.7	7.3	5.7	4.7	7.6	5.8	4.8	7.3	5.6	4.6	7.3	5.6	4.6	7.2	5.6	4.6	150
155	4.6	4.3		6.6	5.4	4.6	7	5.5	4.6	7.3	5.7	4.7	7.1	5.5	4.5	7.1	5.5	4.5	7	5.5	4.5	155
160	4.4	4.2		6.3	5.2	4.5	6.7	5.4	4.5	7	5.5	4.6	6.9	5.3	4.4	6.9	5.3	4.4	6.8	5.3	4.4	160
165				6.1	5.1	4.4	6.5	5.2	4.4	6.8	5.4	4.5	6.6	5.2	4.4	6.6	5.2	4.4	6.6	5.2	4.3	165
170				5.9	4.9	4.3	6.2	5.1	4.4	6.5	5.2	4.4	6.4	5.1	4.3	6.5	5.1	4.3	6.4	5.1	4.3	170
175				5.7	4.8	4.3	6	4.9	4.3	6.3	5.1	4.4	6.2	5	4.3	6.3	5	4.2	6.2	5	4.2	175
180				5.5	4.7	4.2	5.8	4.8	4.3	6.1	5	4.3	6	4.9	4.2	6.1	4.9	4.2	6.1	4.9	4.2	180
185				5.3	4.6	4.2	5.6	4.7	4.2	5.9	4.8	4.3	5.9	4.8	4.2	5.9	4.8	4.2	5.9	4.8	4.2	185
190				5.1	4.4	4.2	5.4	4.6	4.2	5.7	4.7	4.2	5.7	4.6	4.1	5.7	4.7	4.1	5.7	4.7	4.1	190
195				4.9	4.3	4.2	5.2	4.5	4.2	5.5	4.6	4.2	5.5	4.6	4.1	5.6	4.6	4.1	5.6	4.6	4.1	195
200				4.7	4.3	4.2	5.1	4.4	4.1	5.3	4.5	4.2	5.4	4.5	4.1	5.4	4.5	4	5.4	4.5	4	200
205				4.6	4.2	4.2	4.9	4.3	4.1	5.2	4.4	4.1	5.2	4.4	4	5.3	4.4	4	5.3	4.4	4	205
210				4.4	4.1		4.7	4.2	4.1	5	4.3	4.1	5	4.3	4	5.1	4.3	4	5.2	4.3	4	210
215				4.3	4.1		4.6	4.1	4.1	4.9	4.2	4.1	4.9	4.2	4	5	4.2	4	5.1	4.2	3.9	215
220				4.2	4.1		4.5	4.1	4.1	4.7	4.2	4.1	4.8	4.2	4	4.9	4.2	4	4.9	4.2	3.9	220
225				4.1			4.3	4		4.6	4.1	4.1	4.7	4.1	4	4.7	4.1	4	4.8	4.1	3.9	225
230							4.2	4		4.4	4	4.1	4.5	4	4	4.6	4	4	4.7	4	3.9	230
235							4.1	4		4.3	4	4.1	4.4	4	4	4.5	4	4	4.6	3.9	3.9	235
240							4			4.2	3.9		4.3	3.9	4	4.4	3.9	4	4.5	3.9	3.9	240
245							3.4			4.1	3.9		4.2	3.9	4	4.3	3.9	4	4.4	3.8	3.9	245
250										4	3.9		4.1	3.9	4	4.2	3.8	4	4.1	3.8	3.9	250
255										3.9	3.9		4	3.9		4.1	3.8	4	3.6	3.8	3.9	255
260										2.7			4	3.9		4.1	3.8	4	3.1	3.7	3.9	260
265													3.9	3.9		4	3.8	4	3	3.7	3.9	265
270													2.7			3.8	3.8		3	3.4	3.8	270
275																3.2	3.8		2.9	3	3.2	275
280																2.7	3.6		2.8	2.8	2.3	280
285																2.5			2.7	2.8		285
290																			2.6	2.7		290
295																				2.7		295

Lifting capacities

Forces de levage

TNZF 118 ft

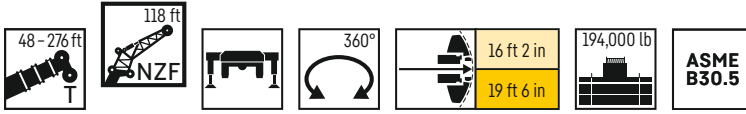

	211 ft			227 ft			243 ft			260 ft			276 ft			
	TNZF 118 ft															
	0°	22.5°	45°	0°	22.5°	45°	0°	22.5°	45°	0°	22.5°	45°	0°	22.5°	45°	
60	10															60
65	9.8			8.6												65
70	9.6			8.5			7									70
75	9.4			8.4			6.9									75
80	9.2			8.2			6.8			4.7						80
85	9			8.1			6.7			4.7			2.9			85
90	8.8			8			6.6			4.7			2.9			90
95	8.6			7.8			6.5			4.7			2.9			95
100	8.4			7.7			6.4			4.7			2.9			100
105	8.2			7.5			6.3			4.7			2.9			105
110	8.1	6.2		7.3			6.3			4.7			2.9			110
115	7.9	6		7.2			6.2			4.6			2.9			115
120	7.7	5.9		7.1	5.6		6.2			4.6			2.9			120
125	7.5	5.7		6.9	5.5		6.1	5.2		4.6			2.9			125
130	7.2	5.5		6.8	5.3		6	5.1		4.5			2.9			130
135	7	5.4		6.6	5.2		6	5		4.5	4.4		2.9			135
140	6.8	5.2		6.4	5.1		5.9	4.9		4.4	4.3		2.9			140
145	6.6	5.1	4.2	6.2	4.9		5.8	4.8		4.4	4.1		2.9	3.4		145
150	6.4	5	4.1	6.1	4.8	4	5.7	4.6		4.3	4		2.9	3.4		150
155	6.2	4.9	4	5.9	4.7	4	5.5	4.5	3.9	4.2	3.9		2.9	3.4		155
160	6	4.7	4	5.7	4.6	3.9	5.4	4.4	3.8	4.1	3.8		2.9	3.4		160
165	5.8	4.6	3.9	5.6	4.5	3.8	5.2	4.3	3.7	4	3.6	3.6	2.9	3.3		165
170	5.6	4.5	3.8	5.4	4.4	3.7	5.1	4.2	3.7	3.8	3.5	3.5	2.9	3.2		170
175	5.4	4.4	3.7	5.2	4.3	3.7	5	4.1	3.6	3.7	3.4	3.4	2.9	3.1	3.2	175
180	5.3	4.3	3.7	5.1	4.2	3.6	4.8	4	3.5	3.6	3.3	3.4	2.7	3	3.1	180
185	5.1	4.2	3.6	4.9	4.1	3.5	4.7	3.9	3.5	3.5	3.2	3.3	2.6	2.9	3	185
190	5	4.1	3.6	4.8	4	3.5	4.6	3.9	3.4	3.4	3.1	3.2	2.5	2.8	2.9	190
195	4.8	4	3.5	4.7	3.9	3.5	4.5	3.8	3.4	3.3	3	3.1	2.3	2.7	2.9	195
200	4.7	3.9	3.5	4.5	3.8	3.4	4.3	3.7	3.4	3.2	2.9	3		2.6	2.8	200
205	4.5	3.8	3.4	4.4	3.8	3.4	4.2	3.7	3.3	3.1	2.8	2.9		2.4	2.7	205
210	4.4	3.7	3.4	4.2	3.7	3.4	4.1	3.6	3.3	2.9	2.7	2.9		2.3	2.7	210
215	4.2	3.7	3.4	4.1	3.6	3.3	4	3.5	3.3	2.9	2.6	2.8			2.6	215
220	4.1	3.6	3.3	4	3.5	3.3	3.9	3.5	3.2	2.8	2.6	2.7			2.5	220
225	4	3.5	3.3	3.9	3.5	3.3	3.8	3.4	3.2	2.7	2.5	2.6			2.4	225
230	3.9	3.4	3.3	3.8	3.4	3.3	3.5	3.3	3.2	2.6	2.4	2.6			2.3	230
235	3.7	3.4	3.3	3.7	3.3	3.2	3.3	3.2	3.2	2.5	2.4	2.5				235
240	3.6	3.3	3.3	3.5	3.2	3.2	3.1	3.2	3.2	2.3	2.3	2.4				240
245	3.5	3.2	3.2	3.4	3.2	3.2	2.8	3.1	3.1			2.4				245
250	3.4	3.1	3.2	3.4	3.1	3.2	2.5	3	3.1			2.3				250
255	3.3	3.1	3.2	3.3	3	3.1	2.2	2.9	3.1			2.3				255
260	3.2	3	3.2	3.2	3	3.1		2.7	3			2.2				260
265	3.1	3	3.2	3.1	2.9	3.1		2.6	2.9							265
270	3	2.9	3.2	2.9	2.8	3.1		2.4	2.7							270
275	2.9	2.8	3.2	2.6	2.8	3.1			2.5							275
280	2.6	2.8	3.2	2.2	2.7	3			2.2							280
285	2.3	2.7	3.2		2.7	3										285
290		2.7	2.9		2.5	2.9										290
295		2.3			2.2	2.5										295

Lifting capacities

Forces de levage

TNZF 141 ft

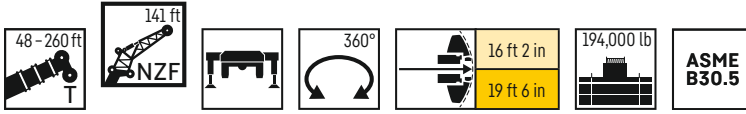

	48 ft			114 ft			130 ft			146 ft			162 ft			179 ft			195 ft			
	TNZF 141 ft																					
	0°	22.5°	45°	0°	22.5°	45°	0°	22.5°	45°	0°	22.5°	45°	0°	22.5°	45°	0°	22.5°	45°	0°	22.5°	45°	
28	20.6																					28
30	20.2																					30
32	19.6																					32
34	19.1																					34
36	18.6																					36
38	18.1																					38
40	17.6			16																		40
45	16.3			15.3			15			14.3												45
50	15			14.6			14.4			13.7			11.4									50
55	13.8			13.8			13.7			13.2			11			10.3						55
60	12.7			13.1			13			12.6			10.7			10			9.3			60
65	11.7			12.3			12.3			12			10.4			9.7			9.1			65
70	10.8			11.6			11.6			11.4			10			9.4			8.8			70
75	10.1			11			11.1			10.9			9.7			9.2			8.6			75
80	9.5			10.5			10.5			10.5			9.3			8.9			8.4			80
85	8.9	7.2		10			10.1			10			9			8.6			8.1			85
90	8.3	6.8		9.6			9.6			9.6			8.7			8.3			7.9			90
95	7.7	6.3		9.1	6.6		9.3			9.2			8.4			8			7.7			95
100	7.2	5.9		8.7	6.3		8.9	6.3		8.9			8.1			7.8			7.4			100
105	6.7	5.6		8.3	6		8.5	6		8.5	6		7.8			7.5			7.2			105
110	6.3	5.3		7.9	5.8		8.1	5.8		8.2	5.8		7.5	5.4		7.3			7			110
115	5.9	5		7.5	5.5		7.7	5.6		7.8	5.6		7.3	5.3		7	5.1		6.8			115
120	5.6	4.7		7.2	5.2		7.4	5.3		7.5	5.4		7	5		6.8	4.9		6.6	4.8		120
125	5.2	4.4	3.8	6.8	5.1		7.1	5.1		7.2	5.1		6.7	4.9		6.6	4.8		6.4	4.7		125
130	4.9	4.2	3.6	6.5	4.9		6.8	4.9		6.9	4.9		6.5	4.7		6.4	4.6		6.2	4.5		130
135	4.6	4	3.4	6.2	4.6	3.6	6.4	4.7		6.6	4.8		6.2	4.5		6.1	4.5		6	4.4		135
140	4.3	3.8	3.2	5.9	4.5	3.4	6.2	4.5	3.5	6.3	4.6	3.5	6	4.4		5.9	4.3		5.8	4.2		140
145	4	3.5	3	5.6	4.3	3.4	5.9	4.3	3.4	6.1	4.4	3.4	5.8	4.2		5.7	4.2		5.6	4.1		145
150	3.8	3.3	2.8	5.3	4.1	3.2	5.6	4.2	3.3	5.8	4.3	3.3	5.5	4.1	3.1	5.5	4		5.4	4		150
155	3.6	3.1	2.7	5.1	3.9	3.1	5.4	4	3.2	5.5	4.1	3.2	5.3	3.9	3	5.3	3.9	3	5.2	3.8		155
160	3.4	2.9	2.5	4.9	3.8	3	5.1	3.9	3.1	5.3	4	3.1	5.1	3.8	2.9	5.1	3.8	2.9	5	3.7	2.9	160
165	3.2	2.8	2.4	4.6	3.6	2.9	4.9	3.7	3	5.1	3.8	3	4.9	3.7	2.9	4.9	3.7	2.9	4.9	3.6	2.8	165
170	3	2.6	2.3	4.4	3.5	2.8	4.7	3.6	2.9	4.9	3.7	2.9	4.8	3.5	2.8	4.8	3.6	2.8	4.7	3.5	2.8	170
175	2.8	2.5	2.3	4.2	3.3	2.7	4.5	3.5	2.8	4.7	3.6	2.9	4.6	3.4	2.7	4.6	3.4	2.7	4.6	3.4	2.7	175
180	2.7	2.4		4	3.2	2.7	4.3	3.4	2.7	4.5	3.4	2.8	4.4	3.3	2.7	4.4	3.4	2.7	4.4	3.3	2.6	180
185	2.5			3.9	3.1	2.6	4.1	3.2	2.7	4.3	3.3	2.7	4.3	3.2	2.6	4.3	3.3	2.6	4.3	3.2	2.6	185
190				3.7	3	2.6	4	3.1	2.6	4.2	3.2	2.7	4.1	3.2	2.6	4.2	3.1	2.5	4.1	3.1	2.6	190
195				3.5	2.9	2.5	3.8	3	2.6	4	3.1	2.6	4	3.1	2.5	4	3.1	2.5	4	3	2.5	195
200				3.4	2.8	2.5	3.7	2.9	2.5	3.9	3	2.6	3.8	3	2.5	3.9	3	2.5	3.9	2.9	2.4	200
205				3.3	2.7	2.5	3.5	2.8	2.5	3.7	2.9	2.5	3.7	2.9	2.4	3.7	2.9	2.4	3.7	2.9	2.4	205
210				3.1	2.6	2.4	3.4	2.7	2.5	3.6	2.8	2.5	3.5	2.8	2.4	3.6	2.8	2.4	3.6	2.8	2.4	210
215				3	2.6	2.4	3.2	2.7	2.5	3.4	2.7	2.5	3.4	2.7	2.4	3.5	2.7	2.4	3.5	2.7	2.3	215
220				2.8	2.5	2.4	3.1	2.6	2.4	3.3	2.7	2.4	3.3	2.6	2.4	3.4	2.7	2.4	3.4	2.6	2.3	220
225				2.7	2.4	2.4	3	2.5	2.4	3.2	2.6	2.4	3.2	2.6	2.4	3.3	2.6	2.3	3.3	2.6	2.3	225
230				2.6	2.4	2.4	2.9	2.4	2.4	3.1	2.5	2.4	3.1	2.5	2.4	3.1	2.5	2.3	3.2	2.5	2.3	230
235				2.6	2.3		2.7	2.4	2.4	2.9	2.4	2.4	3	2.4	2.3	3	2.4	2.3	3.1	2.4	2.3	235
240				2.4	2.3		2.6	2.3	2.4	2.8	2.4	2.4	2.9	2.4	2.3	2.9	2.4	2.3	3	2.4	2.3	240
245				2.4	2.3		2.5	2.3		2.7	2.3	2.4	2.8	2.3	2.3	2.8	2.3	2.3	2.9	2.3	2.2	245
250				2.3			2.5	2.3		2.6	2.3	2.4	2.7	2.3	2.3	2.8	2.3	2.3	2.8	2.3	2.2	250
255							2.4	2.3		2.5	2.3	2.4	2.6	2.2	2.3	2.7	2.2	2.3	2.7	2.2	2.2	255
260							2.3	2.3		2.5	2.2		2.5		2.3	2.6		2.3	2.6		2.2	260
265							2.3			2.4	2.2		2.4		2.3	2.5		2.3	2.5		2.2	265
270										2.3	2.2		2.4		2.3	2.4		2.3	2.3		2.2	270
275										2.3	2.2		2.3			2.4		2.3			2.2	275
280													2.2			2.3		2.3			2.2	280
285																2.2					2.2	285

Lifting capacities

Forces de levage

TNZF 141 ft

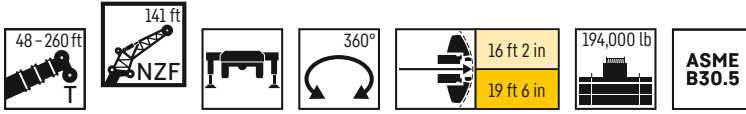

	211 ft		227 ft		243 ft		260 ft		
	TNZF 141 ft								
	0°	22.5°	0°	22.5°	0°	22.5°	0°		
65	7.6							65	
70	7.4							70	
75	7.3		6.2					75	
80	7.1		6.2		4.6			80	
85	6.9		6.1		4.6		2.6	85	
90	6.8		6		4.6		2.6	90	
95	6.6		5.9		4.6		2.6	95	
100	6.4		5.7		4.6		2.6	100	
105	6.3		5.6		4.6		2.6	105	
110	6.1		5.5		4.5		2.6	110	
115	5.9		5.4		4.5		2.6	115	
120	5.8		5.2		4.4		2.6	120	
125	5.6		5.1		4.4		2.6	125	
130	5.4	4	5		4.3		2.6	130	
135	5.2	3.9	4.8	3.6	4.3		2.6	135	
140	5.1	3.7	4.7	3.5	4.2		2.5	140	
145	4.9	3.6	4.5	3.4	4.1	3.1	2.5	145	
150	4.7	3.5	4.4	3.3	3.9	3	2.5	150	
155	4.5	3.4	4.2	3.2	3.8	2.9	2.4	155	
160	4.4	3.3	4	3.1	3.7	2.8	2.3	160	
165	4.2	3.2	3.9	3	3.5	2.7		165	
170	4	3.1	3.8	2.9	3.4	2.6		170	
175	3.9	3	3.6	2.8	3.3	2.5		175	
180	3.7	2.9	3.5	2.7	3.2	2.4		180	
185	3.6	2.8	3.4	2.6	3	2.3		185	
190	3.5	2.7	3.2	2.5	2.9	2.3		190	
195	3.3	2.6	3.1	2.4	2.8			195	
200	3.2	2.5	3	2.3	2.7			200	
205	3	2.4	2.9	2.2	2.6			205	
210	2.9	2.3	2.8		2.5			210	
215	2.8		2.6		2.4			215	
220	2.7		2.5		2.3			220	
225	2.5		2.4					225	
230	2.4		2.3					230	
235	2.3		2.2					235	
240	2.2							240	

Equipment

Crane carrier

Frame	Self-manufactured, weight-optimized and torsion resistant box-type design of high-tensile structural steel.
Outriggers	4-point supporting system, hydraulically telescopic into horizontal and vertical direction. Automatic levelling of crane. Electronic inclination indicator.
Engine	8-cylinder Diesel, make Liebherr, watercooled, output 455 kW (619 h.p.), max. torque 2262 lb-ft. Exhaust emissions to (EU 2016/1628 and EPA/CARB or ECE-R.96, spark arrestor. Fuel reservoir: 214 gallons.
Transmission	Automatic transmission system with torque converter and intarder, make ZF. 12 forward speeds and 2 reverse speeds, transfer case with transfer differential.
Axles	Low maintenance carrier axles, all 6 axles steered. Axle 3, 5 and 6 are equipped with planetary gears, all driven axles with transverse differential locks.
Suspension	All axles are mounted on hydropneumatic suspension - "Niveumatik suspension" and are lockable hydraulically.
Tyres	12 tyres. Size of tyres: 445/95 R 25 (16.00 R 25).
Steering	2-circuit system with hydraulic servo steering. Active speed depending rear axle steering, special steering programs for various driving situations.
Brakes	Service brake: all-wheel servo-air brake, all axles are equipped with disc brakes, dual circuit. Parking brake: Spring brake actuator, acting on the wheels of the 2 nd to 6 th axle. Additional brakes: exhaust flap brake, intarder in gearbox, Telma Eddy current brake (optional).
Driver's cab	Spacious corrosion resistant with comfort furnishings, mounted on rubber shock absorbers, safety glazing.
Electrical system	Modern data bus technique. 24 Volt DC.

Crane superstructure

Frame	Liebherr-manufactured, torsionally rigid steel construction made from high-tensile fine-grain steel. Triple-roller slewing rim.
Crane drive	Mechanical drive of the crane hydraulic from the chassis. Variable axial piston pumps with servo control and power regulation.
Control	Two self-centering control levers (joy-sticks). Pedal switches for telescoping. Infinitely variable crane motions through displacement control of the hydraulic pumps. Additional working speed control by variation of the Diesel engine speed.
Hoist gear	Axial piston variable displacement motor, hoist drum with integrated planetary gear and spring-loaded static brake. Actuation by closed regulated oil circuit.
Luffing gear	1 differential ram with pilot-controlled brake valve.
Slewing gear	Axial piston fixed displacement motor, planetary gear, spring-loaded static brake. Actuation by closed regulated oil circuit.
Crane cab	Large screen area, compound glass, comfort furnishing, cabin tiltable 20° to rear.
Safety devices	LICCON3 safe load indicator, test system, hoist limit switch, safety valves to prevent pipe and hose ruptures.
Telescopic boom	1 base section and 7 telescopic sections. All telescopic sections extendable individually by means of the rapid-cycle telescoping system TELEMATIK. Boom length 48 ft to 295 ft.
Counterweight	149,900 lb
Electrical system	Modern data bus technique. 24 Volt DC.

Additional equipment

K	Double swing-away jib 38 ft - 66 ft Mechanical adjustment 0°, 20°, 40°.
NZK	Hydraulically adjustable swing-away jib 38 ft - 66 ft Hydraulically adjustment 0° - 40°
V	Telescopic boom extension 2 x 23 ft
NZF	Fixed lattice jib 26 ft - 141 ft Hydraulic adjustment 0° - 45°
S	Powerful jib 13 ft - 128 ft
2nd hoist gear	For two-hook operation or for operation with swing-away jib if the hoist rope shall remain reeved.
Tyres	12 tyres. size 525/80 R 25 (20.5 R 25).
Drive 12 x 8	Additional drive of the 4 th axle, all driven axles with transverse differential locks.
Additional counterweight	44,100 lb for a total counterweight of 194,000 lb.
Other items of equipment available on request.	

Équipement

Châssis porteur

Cadre	Construction en caisse résistante à la torsion et optimisée en poids réalisée par Liebherr en acier de construction à grain fin très rigide.
Calage	Dispositif de calage horizontal et vertical en 4 points, entièrement déployable hydrauliquement. Nivellement automatique du calage. Indicateurs électroniques d'inclinaison.
Moteur	Moteur diesel, 8 cylindres, fabriqué par Liebherr, à refroidissement par eau, de 455 kW (619 ch), couple max. 2262 lb-ft. Emissions des gaz d'échappement conformes aux directives (EU) 2016/1628 et EPA/CARB ou ECE-R.96, pare-étincelles. Capacité du réservoir à carburant: 214 gallons.
Boîte de vitesse	Boîte automatique avec convertisseur de couple et ralentisseur, marque ZF. 12 marches AV et 2 marches AR, boîte de transfert avec différentiel répartiteur.
Essieux	Essieux nécessitant peu d'entretien, les 6 essieux sont directeurs. Les essieux 3, 5 et 6 sont des essieux planétaires, tous les essieux moteurs avec différentiel transversal.
Suspension	Suspension hydropneumatique «Niveumatik» - sur tous les essieux. Chaque essieu peut être bloqué hydrauliquement.
Pneumatiques	12 pneus. Taille: 445/95 R 25 (16.00 R 25).
Direction	2 circuits avec direction assistée hydraulique. Direction active des essieux arrière et dépendante de la vitesse, programmes de direction spéciaux pour les différents modes de déplacement.
Freins	Freins de service : servofrein à air comprimé, tous les essieux sont munis de freins à disque, à 2 circuits. Frein à main : ressort accumulé agissant sur les roues des essieux 2 à 6. Freins auxiliaire : par clapet sur échappement, ralentisseur monté sur boîte de vitesse, frein Telma (option).
Cabine	Spacieuse cabine, traitement anticorrosion, équipement «grand confort», suspension par silentbloks, vitrage de sécurité.
Installation électrique	Technique moderne de transmission de données par BUS de données, courant continu 24 Volts.

Partie tournante







































Cadre	Fabrication Liebherr, construction soudée indéformable, en acier à grain fin haute résistance, Couronne d'orientation à triple rangée de rouleaux.
Entraînement	Entraînement mécanique de l'hydraulique de la grue par le châssis de la grue. Pompes réglables à pistons axiaux avec servocommande et réglage de puissance.
Commande	2 leviers à 4 directions avec rappel automatique au point mort. Commande des mouvements progressive en continu par variation de l'inclinaison des pompes et augmentation du régime moteur.
Mécanisme de levage	Moteur hydraulique à cylindrée variable, treuil avec réducteur planétaire à frein d'arrêt à lamelles intégrées, en circuit hydraulique ferme.
Mécanisme de relevage	1 vérin différentiel avec clapet de frein commandé.
Dispositif de rotation	Moteur à cylindrée constante à pistons axiaux, engrenage planétaire, frein d'arrêt commandé par ressort en circuit hydraulique ferme.
Cabine de grue	Construction en tôle d'acier entièrement zinguée avec peinture par poudrage et cuisson au four, avec glaces de sécurité, appareils de commande et de contrôle, équipement confortable. Cabine inclinable vers l'arrière.
Dispositif de sécurité	Contrôleur de charge, «LICCON3», système test, limitation de la course pour le levage, soupape de sûreté contre la rupture de tubes et de tuyaux.
Flèche télescopique	Un élément de base et de 7 télescopes. Chaque partie peut être télescopée individuellement à l'aide du système de télescopage séquentiel rapide TELEMATIK. Longueur de flèche: 48 ft - 295 ft.
Contrepoids	149,900 lb
Installation électrique	Technique moderne de transmission de données. Courant continu 24 Volts.

Équipement supplémentaire

K	Double fléchette pliante 38 ft - 66 ft. Réglage mécanique 0°, 20°, 40°.
NZK	Fléchette pliante à positionnement hydraulique 38 ft - 66 ft. Positionnement hydraulique à 0° - 40°
V	Rallonge flèche télescopique 2 x 23 ft
NZF	Fléchette treillis fixe 26 ft - 141 ft. Positionnement hydraulique à 0° - 45°
S	Fléchette particulièrement puissante 13 ft - 128 ft
2ème mécanisme de levage	Pour l'utilisation du deuxième crochet, ou bien pour une utilisation avec fléchette pliante lorsque le câble de levage principal rest mouflé.
Pneumatiques	12 pneus. Taille: 525/80 R 25 (20.5 R 25).
Entraînement 12 x 8	Essieu 4 est entraîné additionnellement, tous les essieux moteurs avec différentiel transversal.
Contrepoids additionnel	44,100 lb pour un contrepoids total de 194,000 lb.
Autres équipements supplémentaires sur demande.	

Description of symbols

Explication des symboles

	Max. capacity Capacité max.		Outriggers front Calage avant		Radius Portée
	Max. hoist height Hauteur de levage max.		Outriggers rear Calage arrière		Telescopic boom Flèche télescopique
	Max. radius Portée max.		Crane superstructure Partie tournante de la grue		Mechanically/hydraulically adjustable folding jib Pointe pliante réglable mécaniquement/hydrauliquement
	Tyres Pneumatiques		infinitely variable en continu		Telescopic boom extension Rallonge flèche télescopique
	Hookblock/Capacity Moufle à crochet/Capacité de charge		Rope diameter Diamètre		Powerful jib Fléchette particulièrement puissante
	No. of sheaves Poulies		Rope length Longueur du câble		Hydraulic lattice jib Fléchette treillis hydraulique
	No. of lines Brins		Max. single line pull Effort au brin maxi.		
	Weight Poids		Hoist gear Treuil de levage		
	Crane carrier Châssis porteur		Slewing speeds Vitesses d'orientation		
	Driving speed Vitesse de translation		Boom length Longueur de la flèche		
	Gradability Aptitude à graver les pentes		Boom position Position de la flèche		
	Transmission Boîte de vitesse		Counterweight Contrepoids		
	Gear Vitesse		Counterweight radius Rayon de contrepoids		
	Onroad gear Vitesse de route		Outriggers Calage		
	Driving speed - Crawl speed Vitesse de translation - Marche lente		Slewing gear / Working area Mécanisme d'orientation / Plage de travail		
	Max. supporting forces Forces d'appui max.		Standard Norme		

Remarks

1. The lifting capacities do not exceed 85 % of the tipping load according to ASME B 30.5. The crane's structural steelwork is in accordance with EN 13000 and ASME B 30.5.
2. For the calculation of the load charts at least a wind speed of 30 ft/s (9 m/s, 20 mph) and regarding the load a sail area of 1 m² per ton load and a wind resistance coefficient of 1.2 on the load have been taken into account. For lifting of loads with large sail areas and/or high wind resistance coefficients the maximum wind speed as stated in the load charts has to be reduced.
3. The lifting capacities stated are valid for lifting operation only (corresponding with crane classification according to ISO 4301-1, crane group A1).
4. Lifting capacities are given in kip.
5. The weight of the hook blocks and hooks is part of the load and therefore it must be deducted from the lifting capacities.
6. Working radii are measured from the slewing centre.
7. The stated lengths of the telescopic boom are maximum values and may deviate slightly.
8. The lifting capacities given for the telescopic boom apply if the folding jib is removed.
9. Subject to modification of lifting capacities.
10. Lifting capacities above 343,250 lb/374,700 lb only with additional pulley block/special equipment.
11. The data of this brochure serves only for general information. All information is provided without warranty. Instructions for the correct commissioning of the crane please take from the operation manual and the load chart book.
12. The illustrations in this brochure may feature accessories and special equipment not included in the standard scope of delivery.

Remarques

1. La capacité de charge ne doit pas dépasser 85 % de la charge de basculement conformément à ASME B 30.5. La structure métallique de la grue est conforme à EN 13000 et ASME B 30.5.
2. Une vitesse de vent de 30 ft/s (9 m/s, 20 mph) minimum, une surface de prise au vent de 1 m² par tonne ainsi qu'un coefficient de résistance au vent de la charge 1,2 sont pris en compte pour le calcul des tableaux de charge. Lorsque des charges ayant une surface de prise au vent et/ou un coefficient de résistance au vent plus élevé(e)s sont levées, la vitesse de vent maximale indiquée dans les tableaux de charge doit être réduite.
3. Forces de levage pour application de grue de montage (correspond à la classification de grues selon ISO 4301-1, groupe de grues A1).
4. Les charges sont indiquées en kip.
5. Le poids du crochet de levage resp. de la moufle à crochet est une partie de la charge et doit donc être déduit de la capacité de charge.
6. Les portées sont calculées à partir de l'axe de rotation.
7. Les longueurs indiquées pour la flèche télescopique sont des valeurs maximales et peuvent légèrement varier dans la réalité.
8. Les charges indiquées pour la flèche télescopique sont valables lorsque la fléchette pliante est démontée.
9. Charges données sous réserve de modification.
10. Forces de levage plus de 343,250 lb/374,700 lb seulement avec moufle additionnel/equipement supplémentaire.
11. Les données de cette brochure sont données à titre informatif. Ces renseignements sont sans garantie. Les consignes relatives à la bonne mise en service de la grue sont disponibles dans le manuel d'utilisation et le manuel de tableaux de charge.
12. Les figures contiennent également des accessoires et des équipements spéciaux non inclus de série dans la livraison.

MyLiebherr

Our MyLiebherr portal is the easy way for you to access Liebherr's digital service world.
Take advantage of extensive basic and additional services for your mobile and crawler cranes.

Avec notre portail MyLiebherr, accédez facilement à l'univers numérique du service de Liebherr.
Bénéficiez dès maintenant d'un service global et de prestations complémentaires pour vos grues mobiles et sur chenilles.



One portal, all services

MyLiebherr



Planning

Crane Finder



Operations

Performance



Planning

Crane Planner 2.0



Operations

Documents



Maintenance

Spare Parts Catalogue



Planning

LICCON Work Planner



Training

Digital Crane Operator



Maintenance

Parts Shop

Proposition 65



WARNING: This product can expose you to chemicals, including exhaust emissions, including lead and lead compounds, which are known to the State of California to cause cancer, birth defects or other reproductive harm.
For more information see: www.P65warnings.ca.gov/diesel

Subject to modification · Sous réserve de modifications

Liebherr-Werk Ehingen GmbH · Postfach 1361 · 89582 Ehingen, Germany
Phone +49 73 91 5 02-0 · www.liebherr.com

MyLiebherr



Printed in Germany (L)
lwe-tg-318-01-us11-2025